



ProtaSteel 2026

Basic Training Guide

Version 1.0

May 2025

Please get in touch with us for your training and technical support queries

asiastupport@protasoftware.com | globalsupport@protasoftware.com

Publisher



Limitation of Responsibilities

Prota shall not be held responsible for any losses caused by documentation, software, or usage errors.

In addition to Prota License Agreement Terms, it is the responsibility of the user

- to check of results generated by documentation and software,
- make sure that the users of the software and their supervisors have adequate technical capabilities,
- make sure that the software is used correctly per the reference manual and documentation,

Intellectual Property

ProtaStructure is a registered trademark of **Prota Software Inc.**, and all intellectual property rights belong to **Prota Software Inc.** Documentation, training, and reference manuals. Any program component can not be copied, distributed, and used in violation of the license agreement.

Trademarks

ProtaStructure®, **ProtaDetails®**, **ProtaSteel®** ve **ProtaBIM®** are registered trademarks of Prota Software Inc. Prota logo is a trademark of Prota Software Inc.

Table of Contents

Introduction	6
Exporting Model to ProtaSteel.....	6
User Interface	7
Model Explorer	7
Steel Elements and Detailing	7
Intelliconnect Tools.....	8
Edit.....	8
View	9
Zoom and Pan Methods	9
Selection Methods.....	9
Set Workplane	10
User Interface	10
Drawings and Reports.....	10
Drawings.....	10
Numbering.....	10
Material Lists	11
Connection Design Checks	11
Tools	11
Database.....	11
Diagnostic Tools.....	11
BIM	12
Import DXF	12
Import from ProtaStructure	12
Export IFC File.....	12
Export NC Files.....	12
Export to TEKLA	12
Help	13
ProtaSteel Help.....	13
Basic Training Guide	13
Shortcuts	13
About.....	13
Automatic Connection Tools (Macro Gallery).....	14
Macros.....	14
Selecting the Macro Associated with Objects.....	16
Selecting All Objects Associated with a Macro	16
Views and View Settings	16

Creating new Views	18
Automatic View Creation	20
Visibility & Selectability	21
Adjustment of Members by Creating Points	22
Adjustment of Members Orientation and Coordinates	24
Preserve constructive changes during model re-import	26
Steel Connections	27
Base Plate Connection	30
Anchor Bolt	31
Simple Base Plate Connection (Designed)	31
Fin Plate	32
Corner Bolted Gusset Plate Connection (Horizontal Brace)	34
Haunch Connection	35
Bolted Gusset Plate Connection	37
Splice Connection	38
Apex Truss Gusset Connection	39
Truss End Plate With Gusset Plate	40
Welded Pipe Connection	41
Beam to RC Wall/Column Connection	41
Stiffener	42
Sag Rod Holes	44
Sag Rod Connection	46
IntelliConnect For Fully Automated Steel Connection Design	48
Why use IntelliConnect?	48
IntelliConnect Scope	49
Cases Covered	50
How to use	51
Truss Example	52
Purlin Example	53
Beam-Column-Brace Example	54
Beam – Beam – Brace Example	55
IntelliConnect and Connection Ordering	57
Manual Connection (Info Only)	58
Steel Beam to RC Column Manual Connection	58
Steel Beam to Steel Column Manual Connection	64
Connection Design Reports	67
Connection Design Summary Table	69
Collision / Clash Checks	70
Audit Model	71

Detailing Item Manager	72
Preparing Engineering Drawings.....	74
Drawing Module	74
Creating Drawings via Drawing Manager.....	75
Visibility and Selectability in Drawing Module	78
Profile Annotation.....	80
Dimension.....	81
Creating Connection Detail.....	82
Numbering Objects.....	87
Do Numbering	88
Unique Number	88
Rename All.....	88
Reuse Old Numbers.....	88
Modified Part.....	88
New Part.....	88
Creation of Parts and Assembly Drawings	90
Import Titleblock using DXF Import	91
Text & Shapes.....	91
DXF Export	92
IFC File Export	93
Material Takeoff	94
Method 1	94
Method 2	95
NC File Export	96
IDEAStatica Integration.....	97
Closing Summary	99
Thank You	100

Introduction

Thank you for choosing **ProtaSteel** – Steel detailing & connection creation module of the ProtaStructure suite. The primary steel model must be created in ProtaStructure. The model can be exported & opened in ProtaSteel seamlessly. In **ProtaSteel**, you can :

- Model ancillary/secondary steel members such as roof purlins, girts, sag rods, staircase, etc.
- Adjust members to final positions for accurate detailing
- Create and design steel connections
- Create any steel connections manually, save them macro library and reuse them at similar nodes.
- Produce engineering drawings of the steel structure and connections
- Sharing the 3D model created with other BIM platforms such as Tekla Structures.

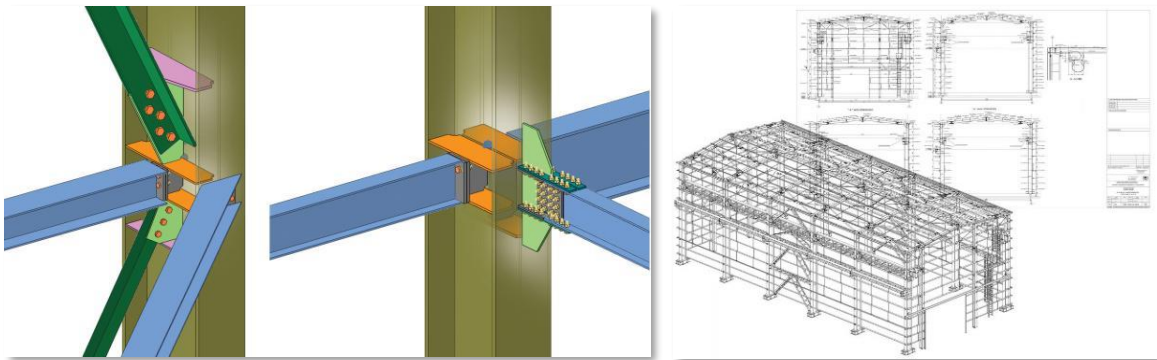

Before you proceed, it is highly recommended you go through ProtaStructure User Guide as knowledge of the fundamentals of **ProtaStructure** is required.

This Quick Start Guide aims to get you up and running quickly. You should be able to learn the fundamentals of **ProtaSteel** in approximately 2 hours by following this simple guide.

Exporting Model to ProtaSteel

A sample steel model is already created & installed in the default installation folder of **ProtaStructure**. We will now open the model, run analysis & export it to **ProtaSteel** :

- Start **ProtaStructure** and the **Open Project** dialog will appear.
- Select & open project “Quick_Start Steel_Complete”
- Go to Analysis → Building Analysis
- Go to **Analysis tab** → Tick Building Analysis → **Start**
- Close the Building Analysis menu

- Go to Drawings & Reports → Load ProtaSteel

ProtaSteel will start and load the project model. ProtaSteel model is created in the subfolder “ProtaSteel” in the project folder.

User Interface

The various components of the ProtaSteel user interface are as shown below:

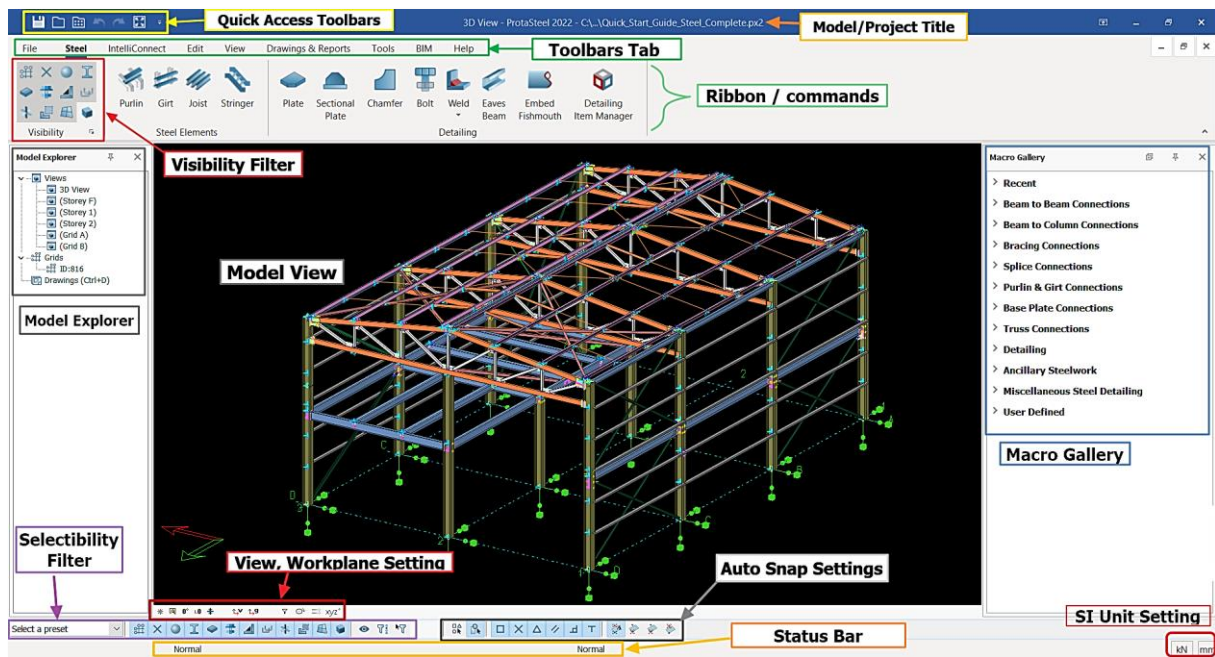

Model Explorer

Default views are created under the “Views” folder in the model explorer pane. By default, the views created are the 3D views & plan views of each story.

Double-click on the desired view in the left-hand Explorer pane to open it. You can open as many views as you like.

The graphical editor supports multiple windows; you can open as many windows as you desire. Modelling can be done both on the plan view and the 3D view.

Steel Elements and Detailing

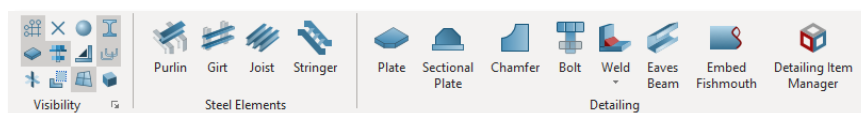

“Visibility” filters are very frequently used commands and are fixed in the top left corners of all menus in the top menu. By using visibility filters, elements that are not wanted to appear on the model can be removed from view.

In **ProtaSteel**, you can only create joist, purlin, girt, sag rod, and stair member (stringer). Primary members such as beam, column & brace must be inserted in ProtaStructure.

Stair members can create both **ProtaSteel** and **ProtaStructure**. But, in the **ProtaSteel**, loads cannot assign to the stair beams and cannot design the sections.

Detailing tools include the manual connection members such as plate, sectional plate, chamfer, bolt, weld, connection detailing item manager, etc.

IntelliConnect Tools

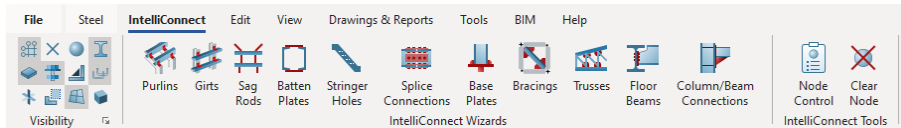

IntelliConnect is an intelligent connection tool that can be applied for different element types. In this menu, quick access to commands separated according to the member type can be provided. These commands can also be accessed from the right-click menu.

More detailed information about IntelliConnect can be found later in the document.

“**IntelliConnect Tools**” are used to clean the information on nodes previously connected by IntelliConnect. For example, you have modelled connections with IntelliConnect on truss elements. But you changed your mind and deleted these macros. Afterward, you should also apply “**Clear Node**” at these points. Otherwise, you cannot model connected with IntelliConnect again.

Edit

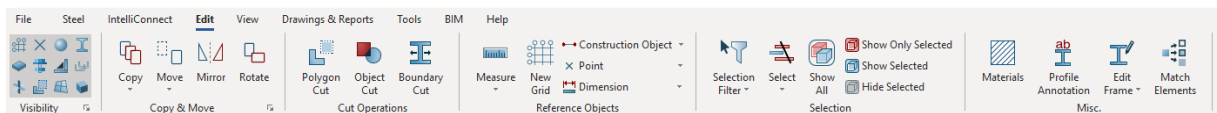

Copy, move, mirror, rotate, cutting objects located in this menu. These commands are also available in the right-click menu.

We can use reference objects such as points, lines, circles while detailing in **ProtaSteel**. These commands are only used during modelling in the interface, and they are not transferred to the drawings.

With selection modes, desired elements can be displayed or removed from view in **ProtaSteel**.

Many parameters such as profile sections, materials, macro types, or element section types can be filtered with the selection filters. At the same time, any assembly or part number in the model can be found quickly with the help of filtering.

Divide and join commands can be applied only to added elements in **ProtaSteel**.

View

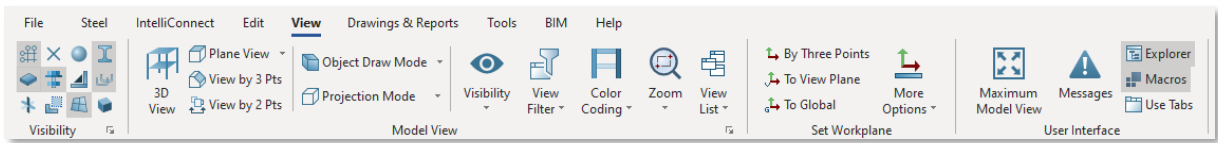

In the **ProtaSteel** interface, we can create a two-dimensional cross-section by showing the two or three points we want on the model.

We can use “with 3 points” to create a plane on the roof. We often use “with 2 points”, especially when making manual connections.

We can set the drawing mode and perspective view of the objects from this menu.

With the color-coding tools, we can show the connection status, material sections, or materials with the color.

Zoom and Pan Methods

The view manipulation is similar to **ProtaStructure**. You will find it easiest to use the mouse wheel to:

- Zoom in** – scroll your mouse wheel up
- Zoom out** – scroll mouse wheel down
- Pan (move)** – hold down the middle mouse wheel and drag
- Rotate** – Right-click & drag



The following keyboard shortcut keys are helpful:

- Zoom All** – **Home** key → Zoom so that all content is visible in the viewport
- Origin of Interest** – **F9** key → Set the center of rotation by clicking on any node or object (such as bolt or plate). The model will then rotate around the selected point.

Selection Methods

Click on an entity to select it.

Hold down the CTRL key and click on the macro to access macro properties.

To select multiple entities, hold down the **CTRL** key while picking them.

You can drag with the mouse to access further selection options:

Drag from **left to right** to create a rectangular box. When you release the mouse button, all entities **wholly contained** within the box will be selected

Drawing a box from **right to left** will select all entities **within** the box and **cross its boundaries**.

To **deselect** all entities, **click** on a space anywhere in the viewport.

Set Workplane

The working plane is essential for using some commands and for the movement of objects, such as copying and moving in the direction we want. By adjusting the working plane to any plane, location, point, or surface we want, we can provide object movement in that plane.

The working plane is indicated in the interface by red and green arrows.

- By 3 Points** – Creates a new workplane by selecting 3 points
- To View Plane** – Moves the workplane to the active view plane
- To Global** – Moves the workplane to the global plane
- To Object** – Moves the workplane to the local coordinate plane of a point
- To Surface** – Moves the workplane to the surface of an object
- To Point** – Moves the workplane to a point
- Rotate and Move** – Rotate and move the work plane

User Interface

The model can be displayed as a full screen in the interface. The side menus with the **“Model Explorer”** and **“Macro Gallery”** can be closed and opened. All views created by clicking the **“Maximum Model View”** button can be viewed and closed collectively.

Drawings and Reports

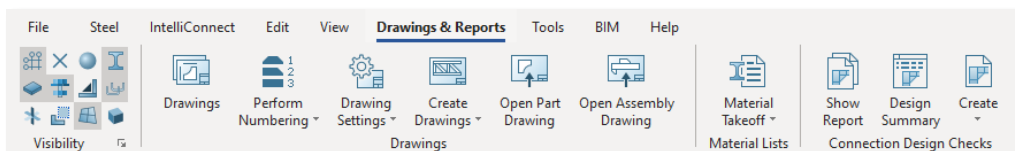

Drawings

“Drawing Module” is opened with the **“drawings”** command on the top menu or double click on the **“Model Explorer > Drawings”**. Also, the **CTRL+D** shortcut can use to open it.

Numbering

ProtaSteel performs the numbering process according to the similarities of all assemblies and parts in the model whose detailing has been completed and whose drawings will be prepared.

Drawings cannot be created without numbering on models with finished detailing. The issue of numbering is explained in detail in the following sections.

Material Lists

ProtaSteel can prepare material lists for all members or selected members on the structural model. In addition to the assembly and part lists, sub-part lists that make up each assembly are also prepared.

The lists are prepared in detail according to the features such as thickness, length, surface area, section type, number of bolts, material quality.

Connection Design Checks

The structural model, whose analysis is completed in **ProtaStructure**, is transferred to **ProtaSteel** with internal forces. **ProtaSteel** uses these internal forces in connection designs. The design code can be selected from the “**Project Preferences**” section in the “**File**” menu.

Calculation reports of a connection can be accessed via the connection’s context menu. The summary table for all connections can be accessed with the “**Design Summary**” command. Design reports for different design codes of the same connection can also be created.

More detailed information on this issue is given in the following sections.

Tools

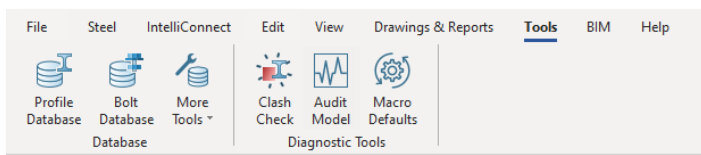

Database

Profile sections used in the building model are defined in **ProtaStructure** and transferred to **ProtaSteel**. Additionally, the profile catalog in **ProtaSteel** can be used for sections such as purlin, girdle, beam to be defined in **ProtaSteel**.

If you cannot find the profile in the **ProtaSteel** profile catalog, you can use it by defining the desired section type in the database. The same method can use for bolt catalog.

Diagnostic Tools

After the connection detailing processes are completed in **ProtaSteel**, clash checks should be done before drawings are prepared. If there are collision problems between the members, the model should be reviewed.

Detailed information on this issue is explained in the following sections.

BIM

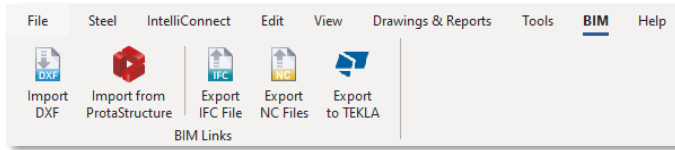

Import DXF

Plans and sections in architectural projects can be exported to ProtaSteel with DXF 2000 file. In particular, this feature allows the control of the architectural project and the manufacturing project by superposing.

Import from ProtaStructure

As known, ProtaStructure exports the structural model to **ProtaSteel**. Similarly, data can also be imported from **ProtaStructure** into a ProtaSteel file.

Export IFC File

The structural model prepared in **ProtaSteel** can save as an “.IFC file”. So, the structural 3D model can also open in the other software.

Export NC Files

CNC machines are generally used to create structural parts. Parts create the assemblies. **ProtaSteel** produces “.NC” files and quickly transfers the part drawings to CNC machines.

Export to TEKLA

The structural model prepared in **ProtaSteel** with all its details can be transferred to Tekla Structures software.

The transfer process is done with a plug-in called TEKLA IO. This plug-in is located on the “Downloads” page of the **ProtaStructure** website. (<https://www.protayazilim.com/downloads>).

You can watch the video about using the plug-in on the **ProtaStructure** Youtube channel.

Help

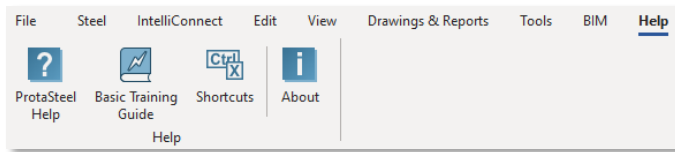

ProtaSteel Help

When guides and reference manuals are needed, users can always click on this option to directly lead them to our **Prota Help Center**.

Basic Training Guide

Basic Training Guide can be very helpful before starting a project or when working on a project. The training guide can always be referred using this link.

Shortcuts

Shortcut keys which can be handy when dealing with repetitive commands. A list of shortcut hotkeys can be found in this link.

About

The company license information and ProtaSteel version and module can be found here. Other than that, Prota Software support contact (e.g. email) can be found here.

NOTE: Press the **F3** key on the keyboard to open the **“Action or Shortcuts”** window. Shortcuts can be changed for the actions.

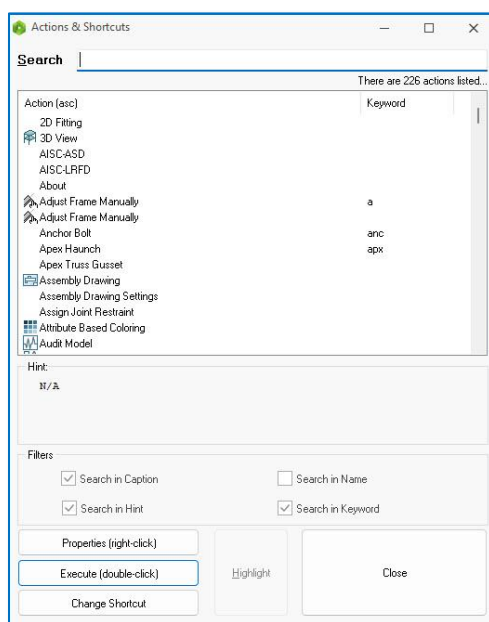

NOTE: All macros and tools have a hint menu. You can find all properties belonging to tools in the hint menu. Wait a few seconds over the tool icons to see the hint menus.

Automatic Connection Tools (Macro Gallery)

The macro gallery is located in the right-side menu in **ProtaSteel**.

Macros are smart connection tools that allow us to model steel connections quickly—for example, fin plate, gusset plate, haunch connection, splice, etc.

All macro types are classified according to the member types they are connecting.

Recent macros can be selected quickly at the top of the macro gallery.



The manual macro command is also at the bottom of the list. The user-defined macro library can be created here.

Detailed information about macros is given in the following sections.

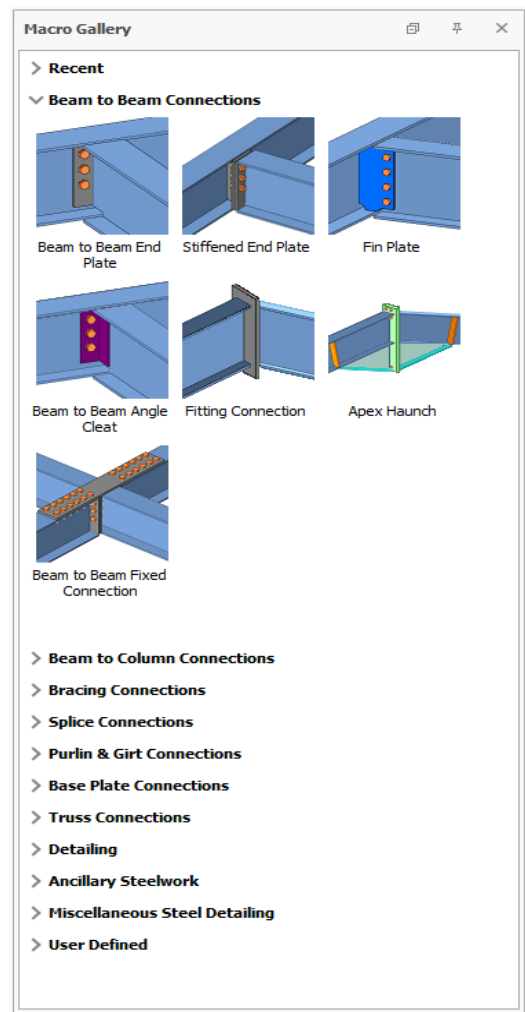
If you hover the mouse cursor over any icons, a tooltip will appear with a detailed explanation of how to use it. You can set the default parameters for each run by right-clicking on the macro icon.



Macros

- A macro is generally defined as a shortcut tool that specifies how a particular input sequence will result in the desired output according to a defined procedure.
- Before creating the macro elements, you can set the macro settings, e.g., member profile, plate offsets, bolts, etc., by right-clicking on the macro icon, which will bring up the Macro dialog.
- Once a macro is clicked, the mouse cursor will change to the hand icon , implying that it is waiting for object(s) selection. A crosshair + icon means that it is waiting for point selection. The tooltip states that perform the required action(s) to get the desired result.
- The macro will remain activated; you can continue using the macro without clicking on the macro icon again.
- Once you have finished, you must press ESC to cancel & stop the macro. The mouse cursor will change back to default arrow  (selection mode).

- After creating the elements in a group, such as the purlins, each element will have its individual properties, which can be changed by double-clicking on it → this will bring up the Element dialog.
- However, all the elements are still associated with the macro & can be changed in a group.
- This can be done by selecting the macro sign  & then pressing ENTER will bring up the macro dialog. After making the changes, clicking Apply will apply to all the elements associated with the macro. Clicking Get will set it to default for this macro for future projects.
- Suppose you have problems selecting the macro sign. In that case, you can choose any element or component of the macro (e.g., a plate of a connection) then press “M” → this will select the macro → hitting the ENTER key will expose the Macro dialog.
- You can select all the elements associated with the macro by selecting the macro sign or an element of the macro → press “CTRL + M”.
- You can also delete all the elements & components of a macro by selecting the macro sign & then hitting DELETE.
- It is highly recommended you review the macro settings before executing them.
- You can reload/clear the changes in the macro default setting by going to Tools (tab) → Macro Defaults → Select macro → Reload/Clear Selected Macro Defaults

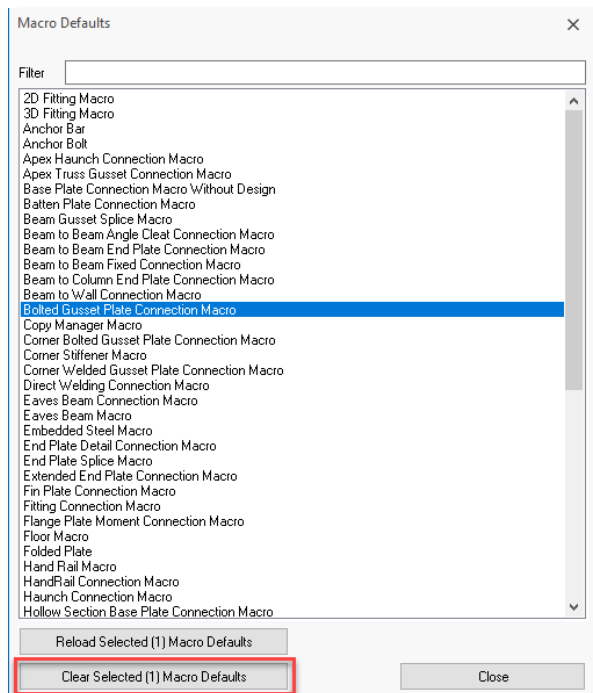

Selecting the Macro Associated with Objects

You can click the Macro icon  on the screen to select the macro associated with any object. However, as the number of objects in the model increases, it may become challenging to distinguish macro symbols. To quickly select the macro associated with any object:

- Select the object. (For example, a plate, a bolt group, or a weld)
- Press **M** on the keyboard. The macro symbol will be selected.
- Press **ENTER** on the keyboard. So, you can open the macro properties window. Press the **DELETE** key to delete/remove the macro or associated objects.

Selecting All Objects Associated with a Macro

In some cases, you may want all objects related to a macro to be selected. For this:

- Select the macro symbol.
- Or select an object created with macro.
- Press **CTRL+M** on the keyboard to select the associated entities.

Views and View Settings

The 3-D view is created by default and displayed on the screen when you open the project. However, plan views at each floor level are also automatically generated.

Views are displayed under the **'Views'** folder in the left project panel.

- Double-click on the desired view in the left project panel will open that view. You can open as many views as you want.

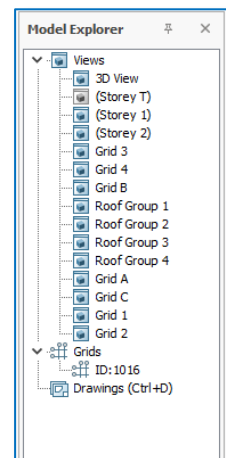

You can open the **View Manager** by double-clicking the Views heading in the build tree.

In the view manager:

- View can open
- View can close
- View can delete
- You can change the view properties

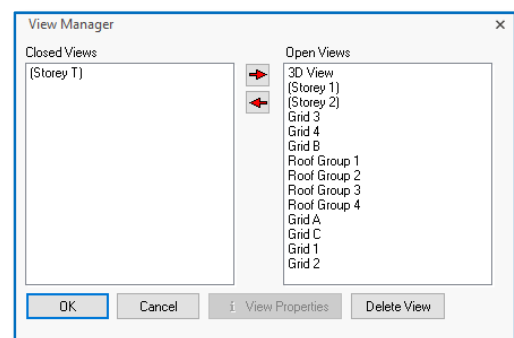

If the multiple views open, you can fit them to the screen by using the **Views > View list> Tile Horizontal / Tile Vertical / Cascade**.

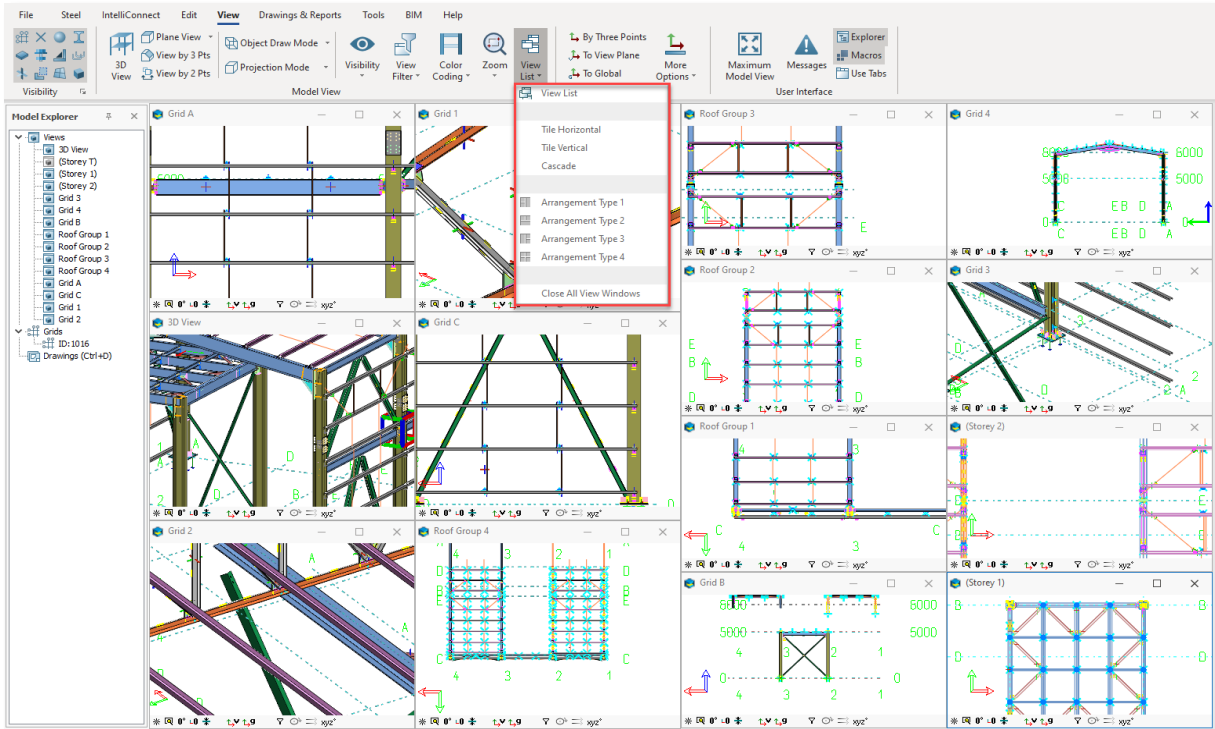

You can change the object draw mode using “**View > Object Draw Mode.**”

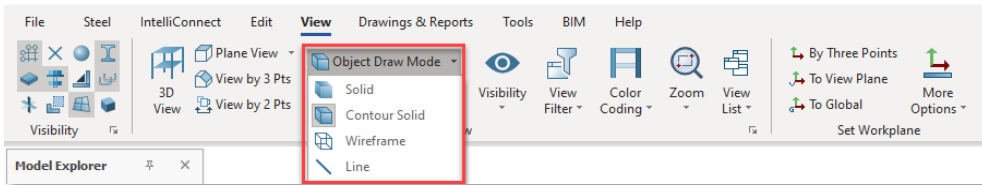

You can cycle through the drawing modes by pressing the **Alt + D** key combination repeatedly

You can specify the 3D view is perspective or orthogonal by using **Views > Projection Modes**.

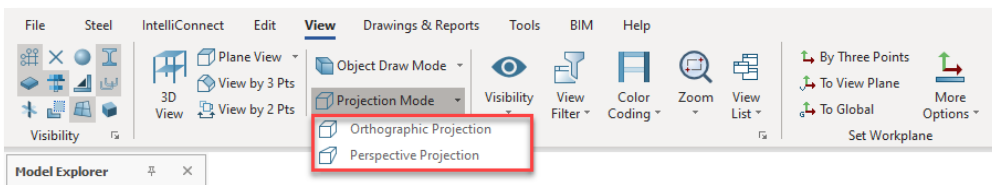

Creating new Views

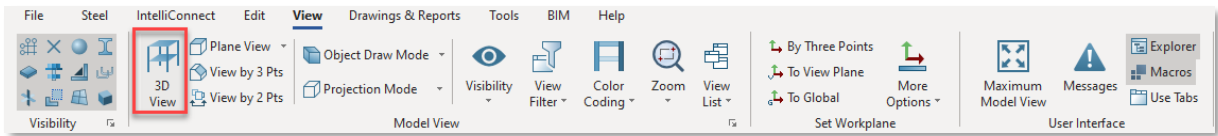

In addition to the 3D view and plan views automatically created in **ProtaSteel**, a new 3D view can be created with the **Views > 3D View**.

To create a quick view at a certain depth by specifying the X, Y, or Z directions of the 3D view, a view can be created according to a particular plane with the **Views > Plan View** option.

For example, selecting **"XY Plane View"** opens a text box for entering a depth value in the plane direction. Let's write a depth value of **5000 mm** in this text box. In this case, the resulting view is added to the building tree by giving the name **"5000 mm elevation plan"**.

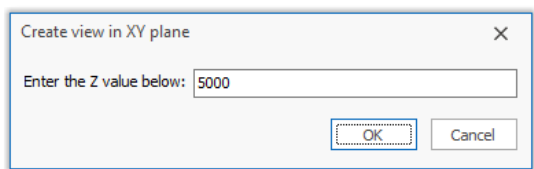

Section views can also be created from the desired region of the building model by selecting 2 points and 3 points.

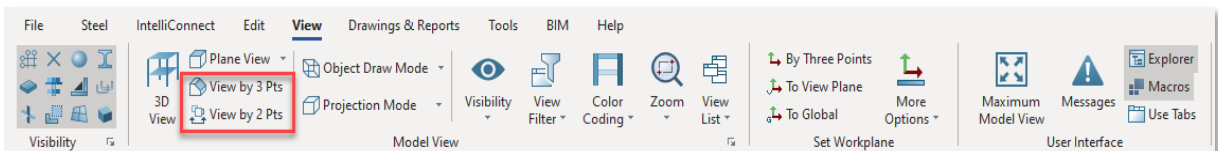

Let us create a new sectional view along grid 3 :

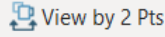
- Go to **Views** (tab) → select **"View by 2 Points."** 
- **Click two points** to define a plane → the view will be created as shown below

A white line arrow will appear once the mouse cursor hovers on 2nd point. This white line indicates the direction of viewing. In this case, the above view is looking into the building.

The coordinate system will be changed according to the current work plane.

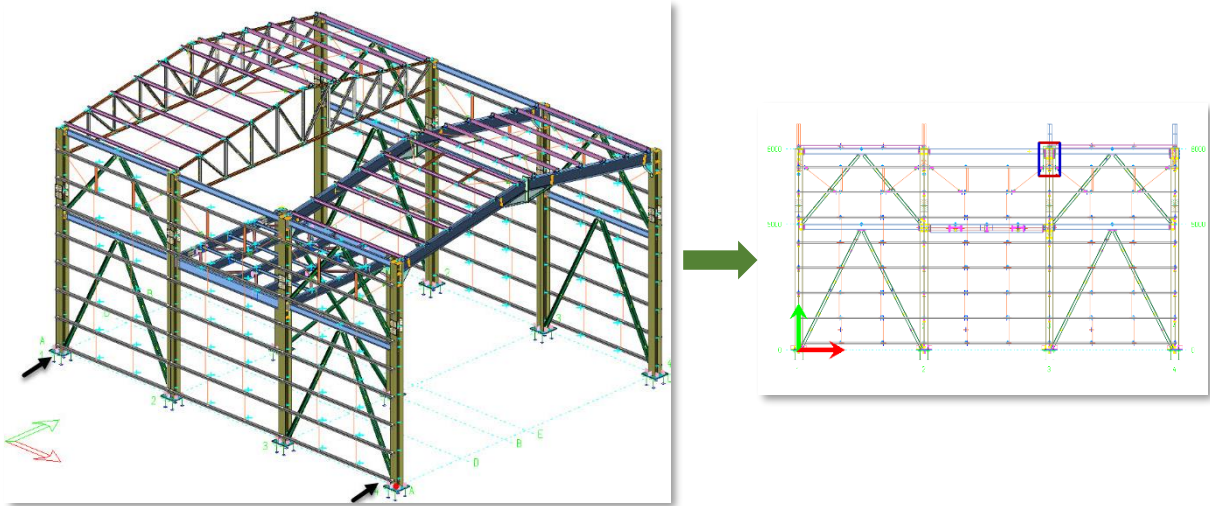

The sectional view is created from the same 3D model but viewed from a different camera angle or orientation. Changes made to the active view are automatically reflected in all other views. The extent, boundary, and objects to display can be set via **View Properties**.

To access the **View Properties**:

- **Double-click** anywhere on the new view → The **View Properties** will appear.

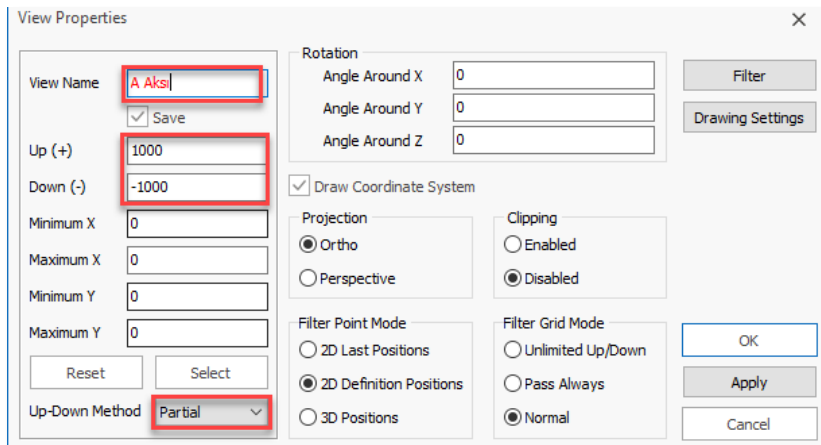

- Give the view a new name, “**Axis A.**”
- Change the **Up(+)** and **Down (-)** to **1000mm** and **-1000mm** respectively.

This means that the view will only show elements 1m into & out of the plane. This will make the view less cluttered as elements along other grids will be hidden. If zero values are entered, then it will be unlimited.

- Up-Down Method:
 - **Partial:** Any element that exists partially within the set extents will be shown
 - **Full:** Only elements that exist entirely within the set extents will be shown

- Click **OK** to close the dialog & the view will be updated.

Any sectional view is inherently a 3D view. Hence you can still rotate the view.

- Right-click and drag to rotate the Axis 3 view. (Notice that only members within the 1 m extent are shown.)
- Go to **View Properties** again.
- Change the Up-Down method in View properties to FULL → Apply (Notice all the beams out of the plane of Axis A will be hidden.)
- Press **F4** to restore lookup (i.e., convert to original viewing direction)

You must give the view a new name and check/tick “Save” to ensure the view is saved. Only saved views can be used to generate drawings in the drawing module.

Automatic View Creation

ProtaSteel can automatically create a 2D section and plan views from all structure axes.

- Select **“Grids”**
- Right-click.
- Select **“Grids > Create Views on Grid.”**

Section and plan views are created automatically from all grid and floor levels. The ProtaSteel automatically labels all sections.

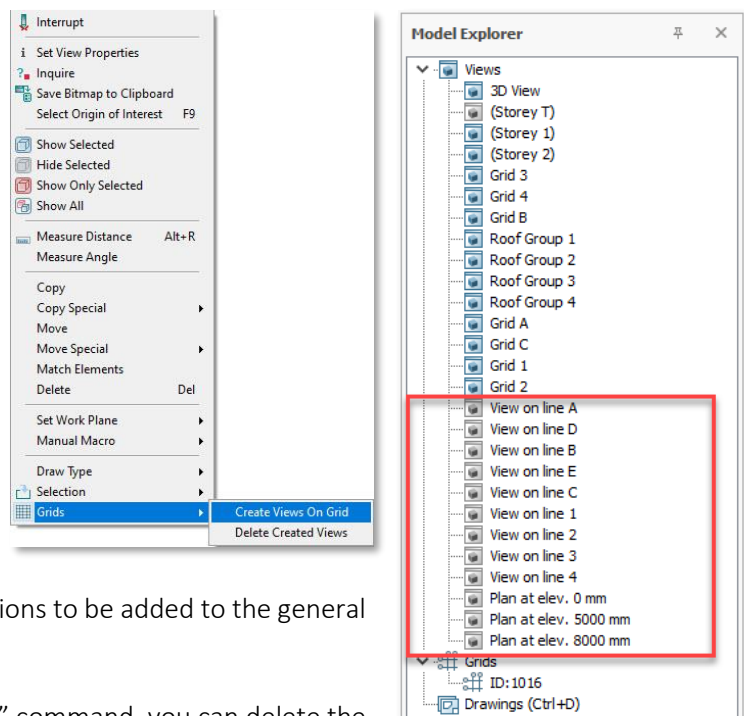

Thus, you can effortlessly create all sections to be added to the general layout drawings.

With the **“Grids > Delete Created Views”** command, you can delete the created views in bulk.

Visibility & Selectability

You can control what objects are visible and selectable by assessing the **Drawing Settings dialog**:

- Double click on the view and pick **Drawing Settings** in the **View Properties** dialog
- Alternatively, click on the **Visibility** icon in the View tab
- Turn off the Grids & Points
- **Apply** and see the effect
- Go back and turn them on

You can **Save As** these different settings as another name to quickly reuse them.

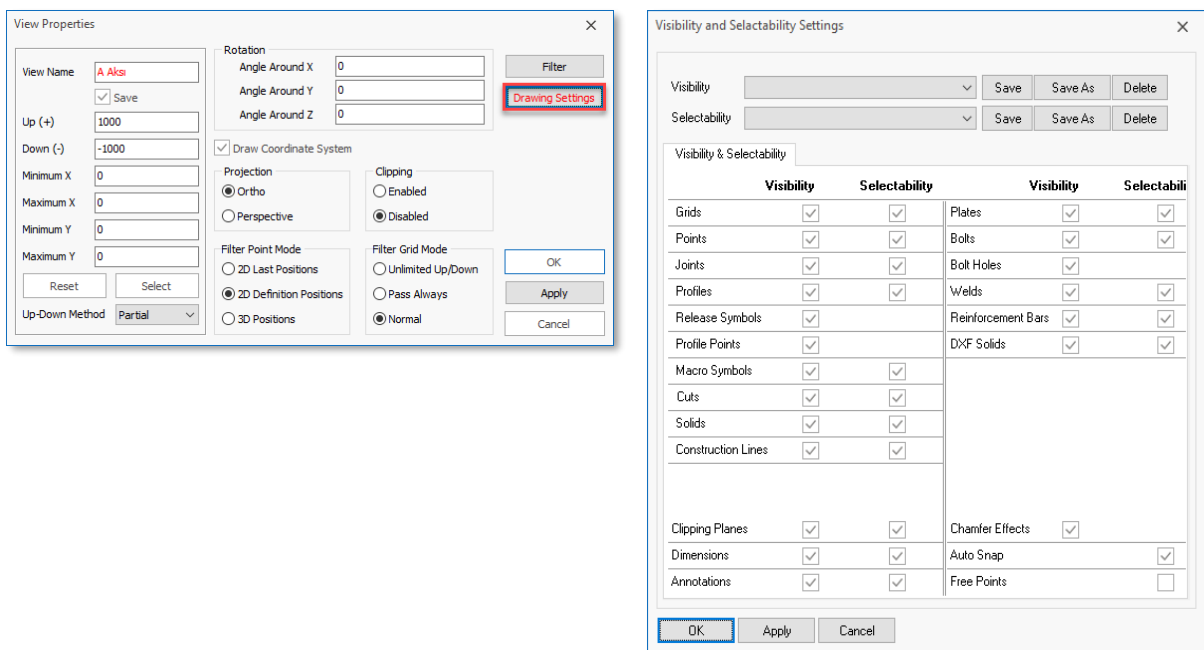

“Visibility” shortcut buttons are also available in the “View” ribbon tab.

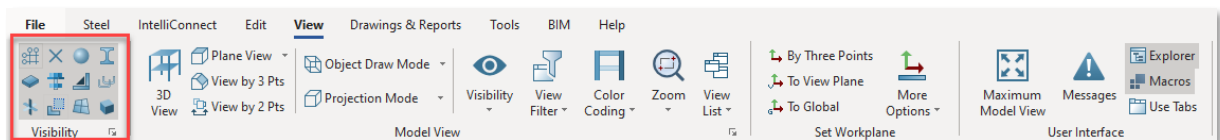

“Selectability” shortcuts are located at the bottom left of the screen in the interface.

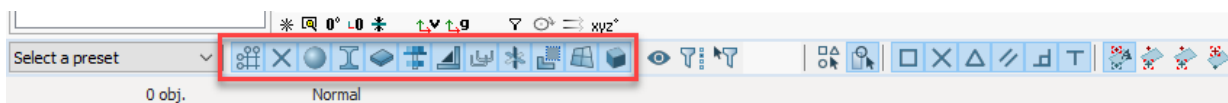

Adjustment of Members by Creating Points

In **ProtaSteel**, you might also want to adjust the position of members that are not precisely at the correct position, i.e., fine-tuning of final member positions for detailing purposes.

In **ProtaStructure**, all the braces inserted will join at the top of beams instead of at the middle (centroid) of the beam. This is because the analytical position of any beam in elevation is at the top of the beam.

The following example is provided for educational purposes. In the models defined in ProtaStructure, truss members such as top chord, bottom chord, diagonal and vertical members, purlins, and braces are defined in their correct positions and transferred to ProtaSteel ready for detailing.

In **ProtaSteel**, detailed tools are available to adjust the positions and fine-tune the members that are not in the correct position. Follow these steps :

- Double-click on the previously created Axis 3 view in the Model Explorer
- Zoom in to the location of the diagonal braces between Grid C and D

As you can see, the diagonal bracings are connected to the top of the beam. It is more accurate for the bracings to join at the middle of the beam.

To do that, we must create a point (or node) in the middle of the beam.

With the point created, we can then move the ends of the bracing to this point.

Note: **Alt + D** key combination can switch drawing modes.

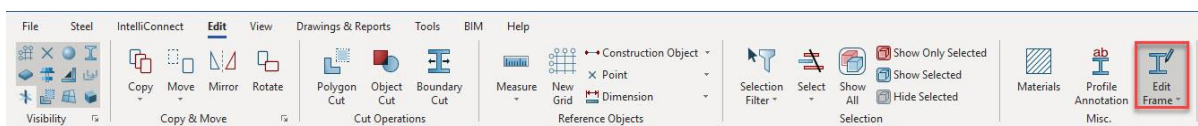
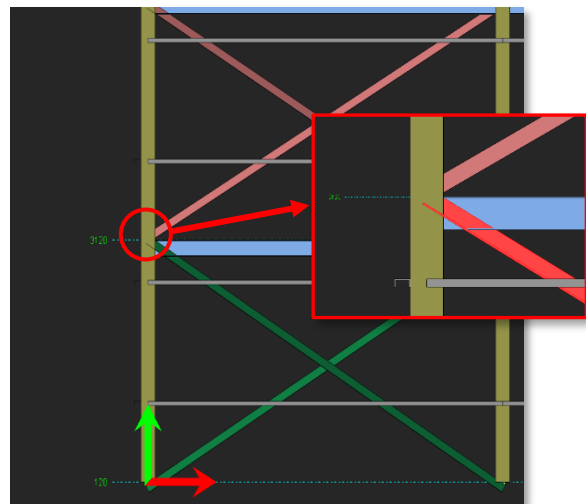

The “Adjust Frame Manually” command is located in the “Edit” menu.

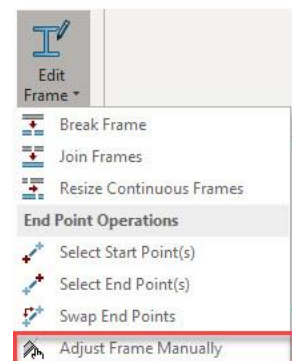

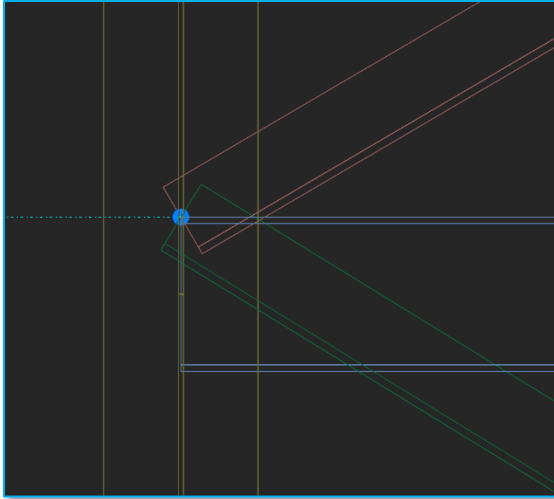

- Press **Alt + D** until you see the outline of members only (wireframe mode)
- Click “**Create Dividing Points**” icon  in Edit (tab) → Point
- **1** – Click top point of the beam
- **2** - Click bottom point of the beam
- A new point “+” is created as shown in the left figure.

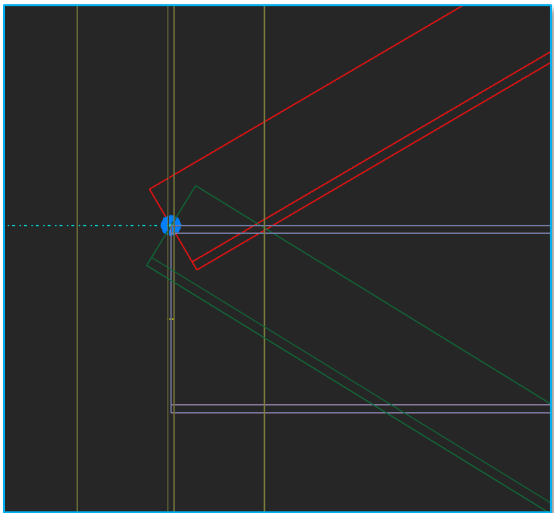

- Click **Adjust Profile Manually** in Edit (tab) → Edit Frame
- **1** – Select the diagonal top bracing
- **2** - Click on existing end point
- **3** - Click on the new point
- The brace end will be shifted to the new point.

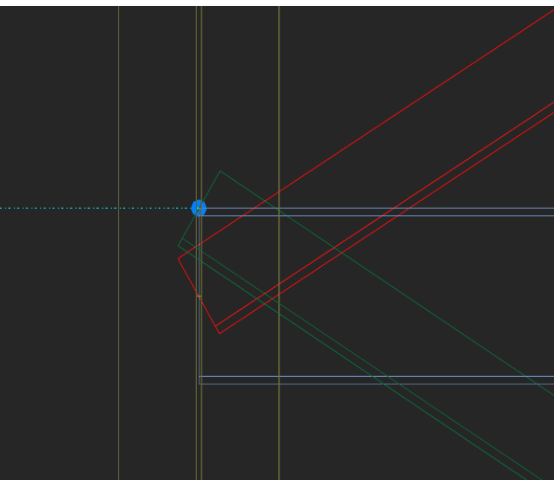

- **Repeat** the above **Step 1 to 3** for the other bottom diagonal brace.
- The final positions of the diagonal braces are as shown in the left figure.
- **Double-click** on **3D View** in the Explorer pane to go to the 3D view.
- **Zoom** in the same location & check the diagonal braces final positions to ensure they are correct.

Adjustment of Members Orientation and Coordinates

All member positions and orientation can also be changed without creating new points. We will make such minor adjustments to some of the floor braces:

- Double-click on **Storey 1** view to open that view
- **Right-click and drag** to rotate it a 3D view
- Zoom to the joint where the secondary, main beam and two horizontal “L” braces meet
- Press **F9** & **click on the joint** to set it as a point of interest so that rotation is about this point

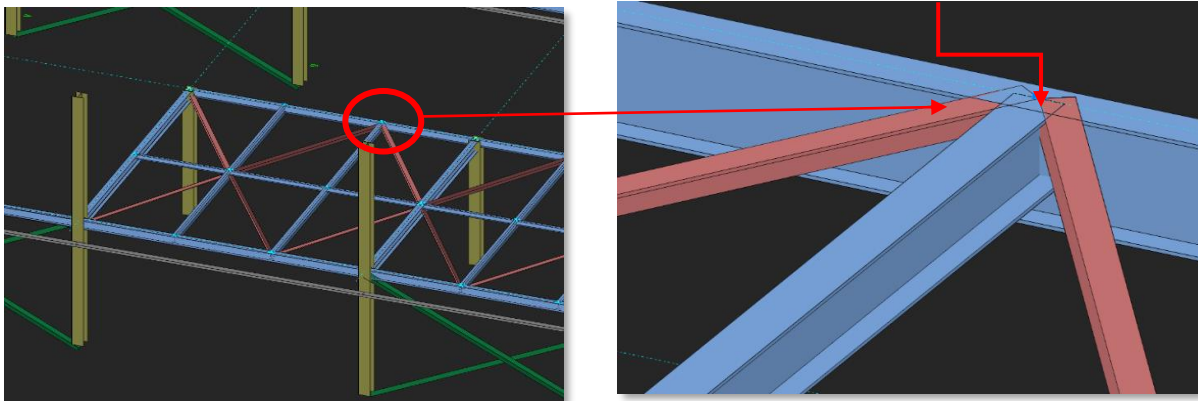

Notice L braces orientation is not symmetrical with the other. We will rotate the brace, so that flange of the brace is aligned with the flange of the beam.

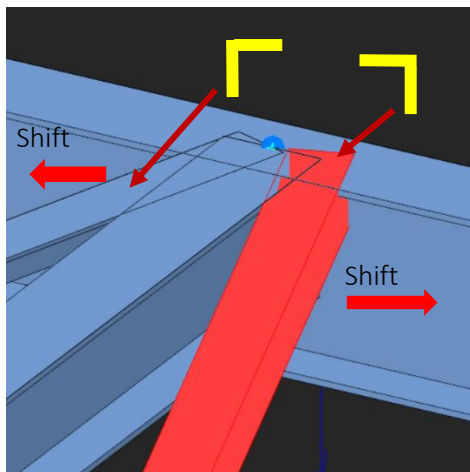

- **Select** the brace
- Press **Ctrl + Q** to rotate it until the correct orientation is achieved as shown in the left figure
- Repeat for the other brace
- The braces are coming in too close to the secondary beam. We can shift it slightly away.
- Press **Ctrl + W** to offset the brace horizontally until it is farthest away from the secondary beam
- Repeat for the other brace

In **ProtaSteel**, **in-Plane** and **Out-of-Plane** holding points of the members and their offset from these points can be adjusted in detail. Members can be defined in-plane and out-of-plane by holding one of the **Back**, **Front**, or **Middle** points.

For example, the truss top chord out of plane alignment is set to top. Since U-shaped sections such as UPN profiles are generally used at the edges of floor openings, In-Plane Alignments are determined as Right or Left. The **Out of Plane alignment** can be adjusted using the object properties window or pressing **CTRL+W** from the keyboard. Similarly, **In-Plane alignment** can be adjusted using the **CTRL+E** shortcut keys.

There is still a problem with the vertical position of the brace as it is too close to the top of the beams. Braces usually should connect to the middle of the beams. This practice ensures force transfer along member centres. In addition, fewer clashes will occur in the connection.

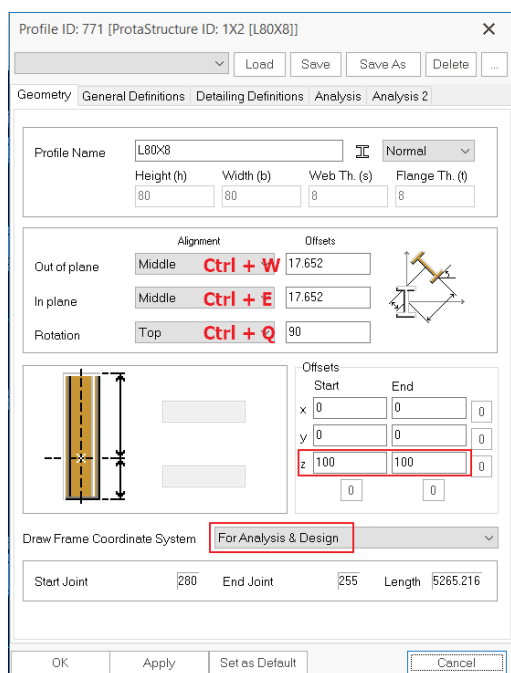

A minor shift in the vertical alignment can be done by pressing **Ctrl + W**. However, if you try this, you will find that the offsets are too small. Further detail adjustment can be done by exposing the **Profile properties**.

- **Double-click** on the right L brace.

Profile Properties dialog allows you to change :

- Profile /Section type by picking “...”
- Alignment (Out of Plane, In-plane, Rotation)
- Offsets Start & End
- Draw Frame Coordinate System
- Change Frame Coordinate System to For Analysis & design → Apply

Notice 3 arrows showing local axis appear at the frame end. **Red** arrow = x-axis; **Green** arrow is y-axis; **Blue** arrow is z-axis.

- If the axes are not visible, please **ALT+D** to change to **Wireframe**
- Enter z Start & End Offset to **100 mm** → Apply
- Check the 3D view to ensure brace is moved down
- **Repeat** for the other brace (**-100mm**) → **OK** to exit

In-plane and **out-of-plane** alignment and offset values shift both ends of the members in a parallel plane. In cases where the two ends will move differently, you can use the x, y, z **“Start”** and **“End”** offset values at the bottom of the window. These values work in the direction of the members’ local axes. You usually will not need to use these offset values. Necessary adjustments in these fields are made automatically by macros.

While working in **ProtaSteel**, the **In-Plane** and **Out-Plane** will be enough for the position changes you will make on the members.

Preserve constructive changes during model re-import

There is a one-way data transfer from **ProtaStructure** to **ProtaSteel**. Adding and removing a new member to the project must be done in **ProtaStructure**. In this case, the project must be saved and closed in **ProtaSteel**, and necessary changes must be made in **ProtaStructure**.

If it is desired to keep the changes made before in **ProtaSteel** (e.g., member position & orientation), the **“Preserve constructive changes during model re-import”** option must be marked.

In the **General Definitions** tab, the option **“Preserve constructive changes during model re-import”** is by default checked.

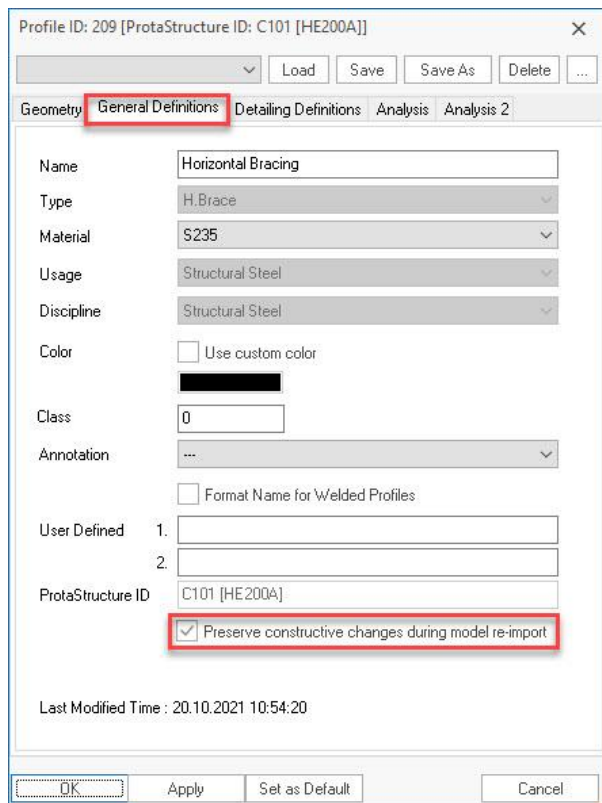

During the next import, the import log file will show a warning :

“Imported Frame's ID in *.cdf file[xxx]: Frame is locked. Therefore, in plane, out of plane and start/end offsets were not applied.”

Ignore the above warning (log file) if you want the member offsets to be retained in **ProtaSteel**.

If this option is unticked (disabled), offsets done in **ProtaSteel** will be discarded during the next re-import from **ProtaStructure**.



Steel Connections

Once we have finalized the position of the steel members, we can start “connecting” the steel members, i.e., create connections. Connections can be created in two ways:

1. Automatically using the connection macros from **Macro Gallery** or **IntelliConnect**
2. Manually by using the Plates, Bolts, Welds & Cuts commands

The automatic connection macros will automatically create the appropriate connection. If internal forces are transferred from **ProtaStructure**, they will be automatically considered in the connection design.

Detail design check is performed for the following connections per Eurocode 3, AISC (LRFD), AISC (ASD), BS5950.

- Beam to Beam Connections: End Plate, Stiffened End Plate, Fin Plate
- Beam to Column Connections: End Plate, Stiffened End Plate, Fin Plate
- Beam to Beam End Plate Connection
- *Haunch Connection
- *Direct Welding Connection
- Apex Haunch Connection
- Simple Base Plate Connection
- Flange Plate Moment Connection
- Extended End Plate Connection
- Bolted Gusset Plate Connection
- Corner Bolted Gusset Plate Connection
- Welded Gusset Plate Connection
- Corner Welded Gusset Plate Connection
- Splice Connection

Important: Base plate connection design can be performed in **ProtaStructure**. The designed details can then be applied to the model in **ProtaSteel** using the base plate macro.

A detailed design report can be produced for the connections mentioned above, including geometric and capacity checks. In addition, intermediate calculations, references to the appropriate clauses of the design code, and corresponding equations are shown for easy checking.

Note: ProtaSteel has the feature of transferring data to the **IdeaStatica** connection program. With this feature, connections created with macros and user-defined complex connections can be transferred to the IdeaStatica program and connection calculations can be checked with the finite element method.

For the above connections, the following basic material strength checks are performed:

- Plate bearing check
- Bolt shear & Bolt tension check
- Weld stress check
- Plate tension & plate bending check

The checks above are the basic material checks, not clause-by-clause code-specific checks. No design report can be produced. You are advised to perform your additional calculation checks if required.

The force used in the automatic connections are obtained from the higher of the two values :

1. The critical design forces of the connected members imported from **ProtaStructure**
2. User-defined **Capacity Ratio** in the Profile Properties > **Detailing Definitions**.

Capacity Ratio = Design Force / Maximum Member Capacity (equal less than 1)

This approach prevents unrealistic design when the design forces are very small or negligible.

For example, in the determination of the number of the bolts for a simple beam to beam fin plate :

- The critical design shear imported from ProtaStructure is 30 kN. This requires 1 number of bolts.
- The Shear Capacity Ratio of the beam is set to 0.3. This works out to be 100 kN which requires two bolts.
- The final design shear force used is 100kN; Two bolts are chosen.

There is no check or design at all for the following connections:

- Beam to Beam Angle Cleat Connection
- Fitting Connection
- Beam to Beam Fixed Connection
- Wind Column Connection
- Base Plate Connection Without Design (Connection calculation can be design in ProtaStructure)
- Knee Connection
- Beam to Wall Connection
- End Plate Splice Connection

- Purlin and Girt Connections
- Eaves Beam Connection
- Hollow Section Base Plate Connection
- Sag Rod Connection & Sag Rod Holes
- Welded Pipe Connection
- Welded Box Connection
- Beam to Wall Connection
- Apex Truss Gusset Connection
- Truss Seating Connection
- RC Column Truss Seating Connection
- Embedded Steel Connection
- Truss End Plate with Gusset Plate Connection
- Stiffened Base Plate Connection
- Batten Plate Connections

* Denotes : Check is provided but will not automatically design the number of bolts and size of the plates. It will be provided with a default connection size and will require user to manually adjust the connection in the connection macro setting if the design has failed.

Before performing connection design, we should customize the default design parameter :

- Go to File → **Settings** → **Project Preferences**
- Ensure that Design Standards for Connections is set to **EC3**
- General Overdesign Factor for Connections = **1**

The connections will generally design for 100% of the member capacity. This setting works in combination with **capacity ratios** of the connecting members (changed via Profile dialog → **Detailing Definitions**). The Capacity Ratio is automatically calculated = Design force divided by the actual capacity of the member. Hence, **Capacity Ratio x Overdesign Factor = Final Factor**.

- For example, under Steel Detailing, ensure the following
 - **Plates** : Preferred Plate Material = **S355**
 - **Bolts**: Preferred Bolt Material = **Class 8.8**
 - **General Weld**: Preferred Weld Material = **Class 42**

- Apply → OK

Base Plate Connection

To create a base plate connection to columns, we can use the base plate macros from **Macro Gallery**. There are four base plate macros in **ProtaSteel** for creating the base plate connection. This macro can design and create calculation reports.

- Base Plate Connection (without design)
- Simple Base Plate Connection (with design)
- Hollow Section Base Plate (without design)
- Stiffened Base Plate
- Shear Key

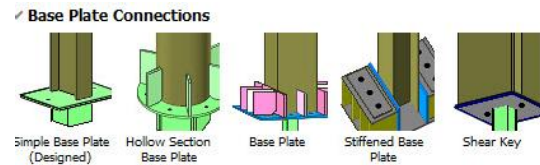

Base plate connection design can be performed in **ProtaStructure**. The designed details can then be applied to the model in **ProtaSteel** using the base plate macro.

In **ProtaSteel**, restraints are indicated with the ball and cubic objects in green. If the connection is defined as a moment connection in **ProtaStructure**, it is shown with a ball + cubic object. If the connection is designed as a pinned connection, it is illustrated with only a ball object.

Using “**Base Plate Macro**”, all fixed and pinned connections are created.

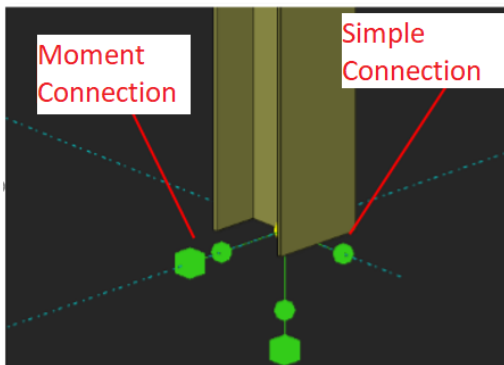

- Select the “**Base Plate Connection Macro**”
- Select the **column**.
- The connection is created under of column.

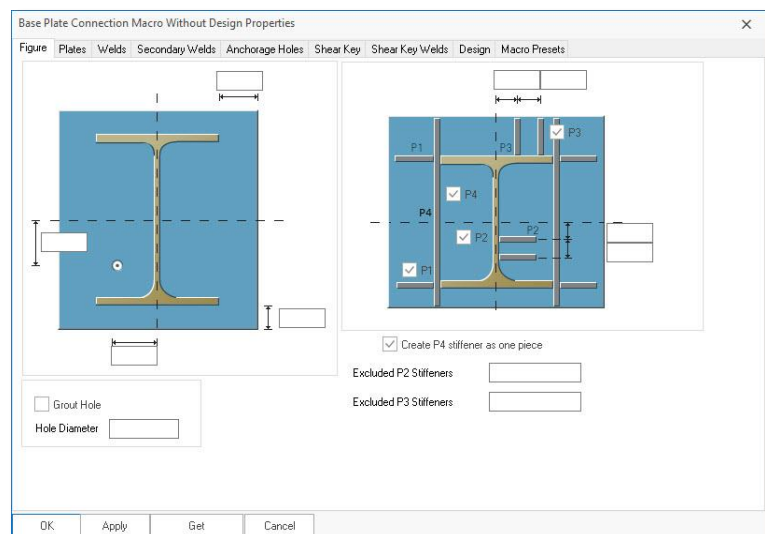
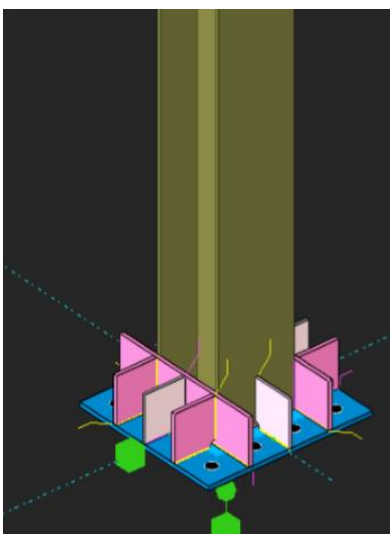

Anchor Bolt

Anchor bolts can be added to the holes on the base plates. Anchor bolts can be created on the holes by selecting one by one or only the plate.

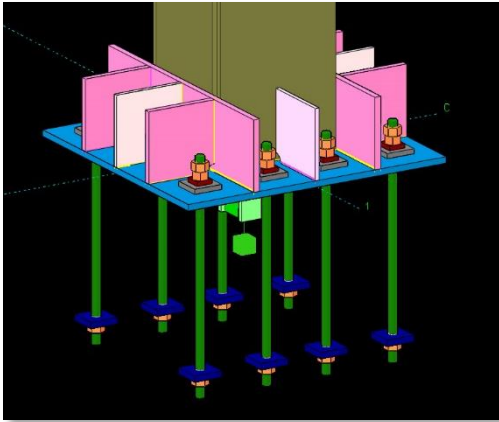

- Select the **“Anchor Bolt”** from the **“Miscellaneous Steel Detailing”** tab.
- Right-click. The cursor changes as a hand shape.
- Select the **base plate**.
- The anchor bolts are created on the holes of the base plate.

Simple Base Plate Connection (Designed)

The **“Simple Base Plate Macro** can create pinned connections”. This macro can design and create calculation reports. All parameters can be changed in macro properties.

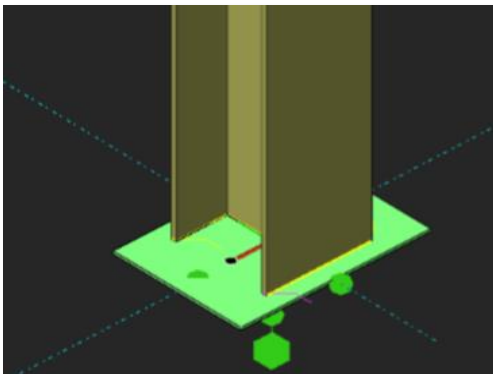

- Select the **“Simple Base Plate Connection Macro”**
- Select the **column**.
- The connection is created under of column.

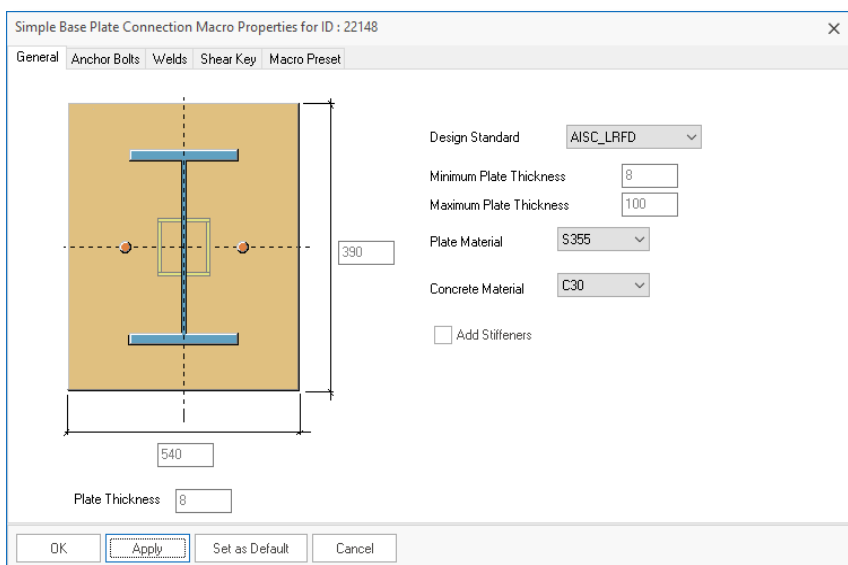

Fin Plate

We will create a **fin plate connection** between the main and the secondary beam.

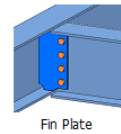

- Right-left-click on the **Fin Connection Macro** under Beam to Beam Connections from **Macro Gallery**
- The Fin Plate Macro dialog will appear, which allows you to customize the connections.
- Go to the **Design Tab** and ensure the following :
 - Design Standard = EC3
 - Pick **Get** to make it **default** settings for this connection type for all projects from now on.
 - Zoom in where the two braces and one secondary beam connect to the main beam.
- **Double-click** on the secondary beam
- In Profile Properties, go to the **Detailing Definitions** tab.

Slip Coefficient is blank and hence will follow the Project Preferences → Bolts settings

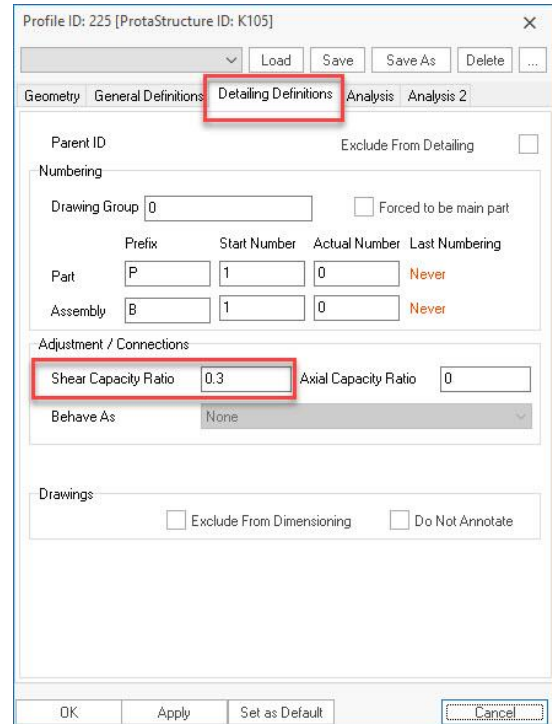

- The **Capacity Ratio** is **0.3** for this beam, by default.
- This will be used to calculate the minimum design shear used for the connection.
- The **Analysis tab** shows the geometric properties of the member.
- Apply → OK

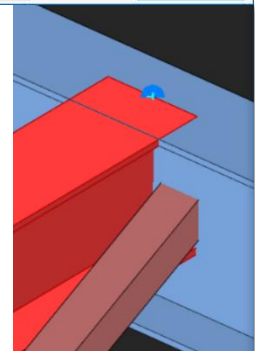

The capacity ratio works in combination with General Overdesign factor for Connections (in Project Preference).

Hence, Capacity Ratio x Overdesign Factor = Final Factor.

- Select “Fin Plate Connection”
 - 1 – Select main beam
 - 2 – Select secondary beam.
- **Right-click 3 times** (to pass other parameters of the macro without entering values)
- The **Fin Plate Connection** will be created automatically.
- Click on the secondary beam, under the Detailing Definitions tab, change the Shear Capacity Ratio to 0.1. This is because the shear capacity of the secondary beam is much higher than the actual shear.
- If you need to adjust the bolts and plate layout, click on the blue plate, press M and press Enter to call out the Macro Properties.

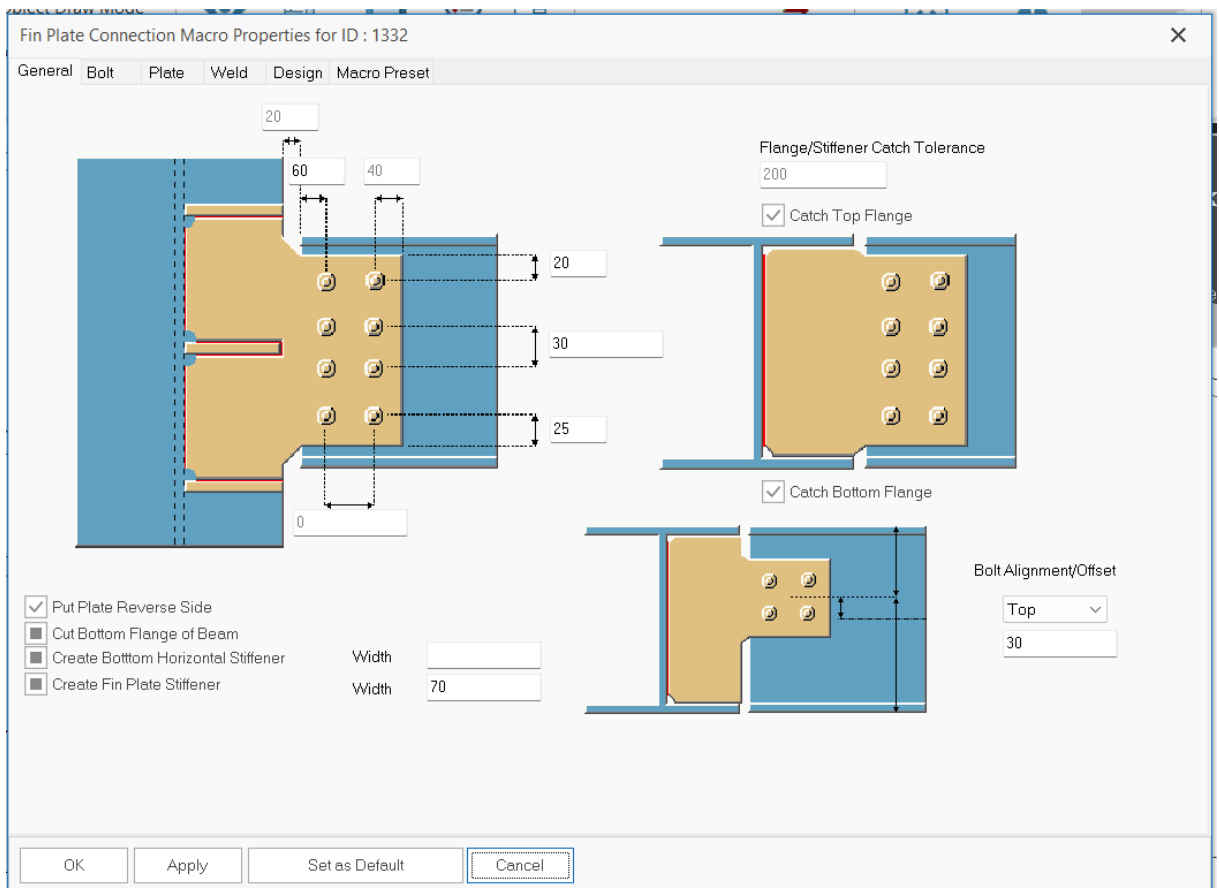
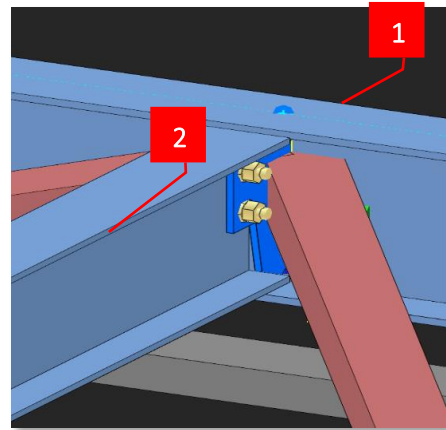

Corner Bolted Gusset Plate Connection (Horizontal Brace)

We will insert a corner bolted gusset plate for the L brace that uses the beam fin plate as the boundary.

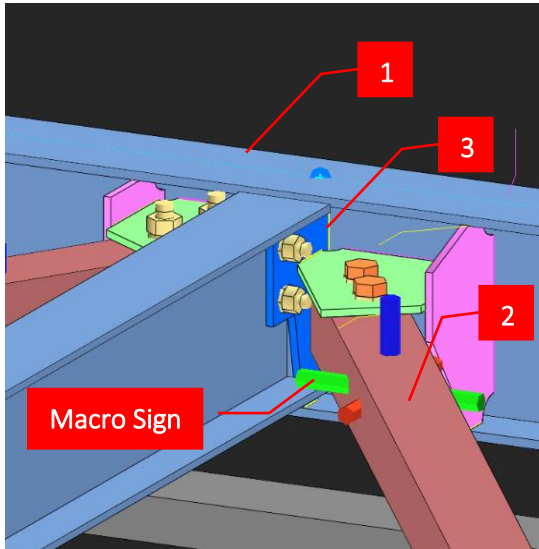
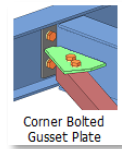

- Pick **Corner Bolted Gusset Plate Connection** under Bracing Connections from Macro Gallery
 - 1** – Pick the main beam
 - 2** – Pick the brace
 - 3** – Pick the blue fin plate
- The connection is created. Repeat the same for the other brace.

- The connection consists of plates, bolts & welds. Each members has its individual properties and can be selected, deleted, or changed. **Double-clicking** it will reveal the member properties.
- The entire connection is represented by the macro sign . **Double-clicking** on it will bring out the Macro dialog box where the entire connection can be changed.
- It is highly recommended you review settings of the connection macro before executing it.

Beam to Beam End Plate Connection

We will create **Beam to Beam End Plate Connection** between the primary and secondary beam.

Zoom to the adjacent joint where the secondary & primary beam meet.

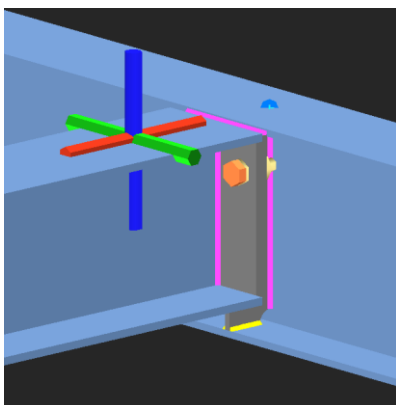
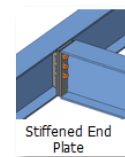

- Pick **Stiffened End Plate Connection** under Beam to Beam Connections from Macro Gallery
 - 1** – Pick the main beam
 - 2** – Pick the secondary beam
- The connection is created. This maybe a preferable in terms of load transfer & ease of assembly & construction.

Haunch Connection

We will create a haunch connection between the column and beam.

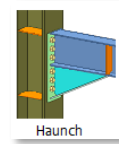

Let's change macro default values before creating the connection. We can also change the properties after making the connection.

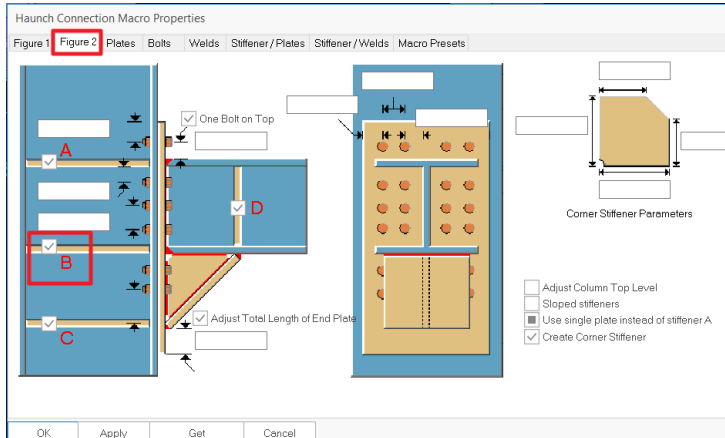

- Right click on the **Haunch Connection** under Beam to Column Connections from Macro Gallery
- Go to **Figure 2** tab
- Ensure that all the **end plates A,B,C & D** is checked
- Apply → OK to exit

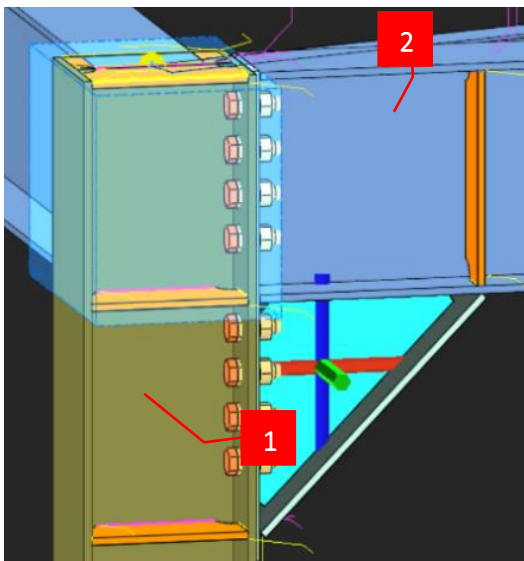

We will now insert the haunch connection.

- Pick Haunch Connection
- **1** – Pick the column
- **2** – Pick the beam
- The connection is created. The blue transparent box is the cut object. This can be turn on/off in Visibility dialog.

Repeat the same for the other end of beam to column joint

Stiffened End Plate Connection

We will create a stiffened end plate connection at the column beam joint at **grid C/3**.

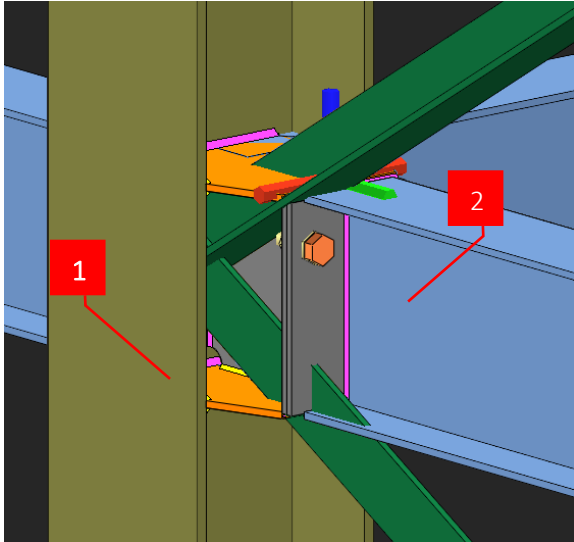
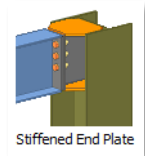

- Double-click on **Axis 3** view to open view
- Zoom in the joint where the column, beam and 2 diagonal braces meet at **grid C/3**
- Press **F9** on this joint to set the point of interest
- Rotate the view slightly about this joint
- Pick Stiffened end plate connection from Macro Gallery
- **1** – Pick the column
- **2** – Pick the beam
- **Right-click** → Connection is created

Corner Bolted Gusset Plate Connection (Vertical Brace)

We will connect the diagonal brace at the same joint. There is a problem because the existing connection is getting in the way, i.e., we cannot connect the diagonal brace directly to the column due to the top stiffener plate. This can be solved by using the **Corner Bolted Gusset Plate Connection**.

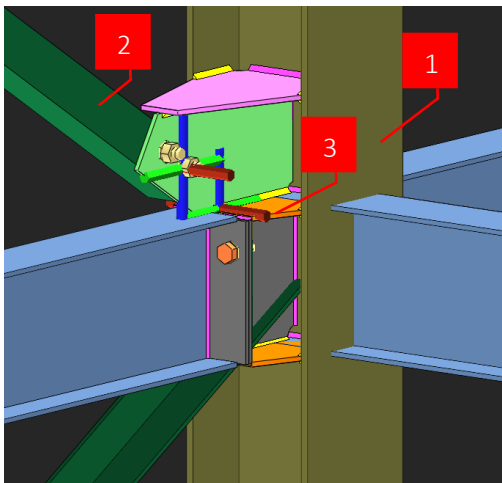
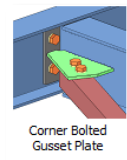

- **Rotate** the view around so the connection is not obstructed by the girt
- Pick **Corner Bolted Gusset Plate Connection** under Bracing Connections from Macro Gallery
- **1** – Pick the column
- **2** – Pick the top brace
- **3** – Pick top orange plate
- A logical & constructible gusset plate connection will be created joining the top plate of the previous connection.
- After the connections are successfully inserted. Change the number of bolts in the macro properties.

Bolted Gusset Plate Connection

It is slightly different for the bottom brace as it should directly connect to the beam flange's bottom.

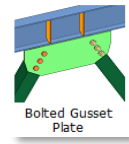

Hence, we should use the **Bolted Gusset Plate Connection**.

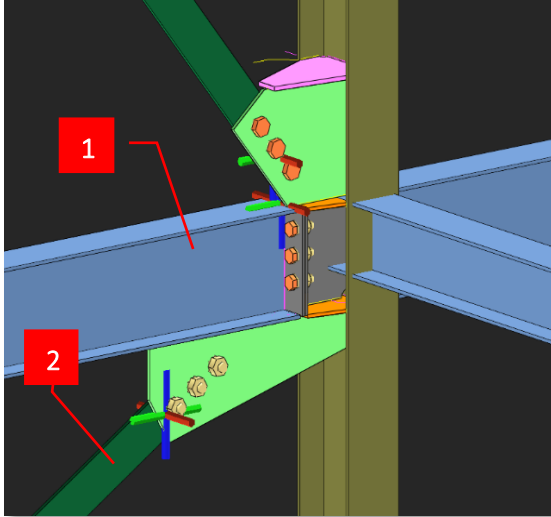

- **Rotate** the view around the connection so you are viewing the bottom of the brace
- Pick **Bolted Gusset Plate Connection** under Bracing Connections from Macro Gallery
 - 1** – Pick the beam
 - 2** – Pick the bottom brace
- Right-click
- A logical & constructible gusset plate connection will be created joining the bottom flange of the beam.
- Press **ESC** to cancel the macro

For constructability, let's push back & shorten the green gusset plate to terminate precisely at the beam end.

- **Select** connection macro by selecting the macro sign  → Press **Enter**
- Alternatively, select the gusset plate > press **"M"** > Press **Enter** (wait for the macro dialog)

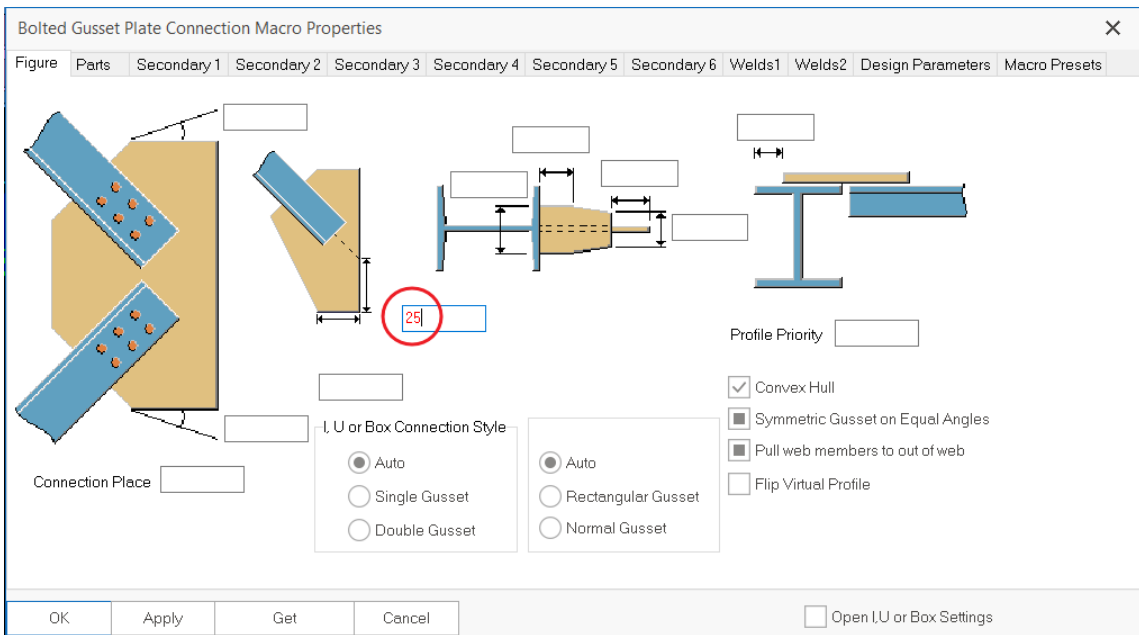

Enter **25mm** in the above plate **set-back** value → **Apply**

The plate is shortened, and the stiffener plate is added.

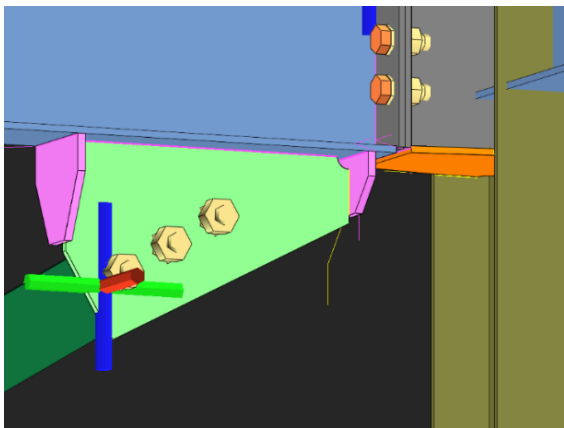

- This is more constructible because the gusset plate & stiffener can be assembled off-site as part of the beam assembly.
- The previous stiffened end plates will be part of the column assembly.
- Hence, when the column & beam are brought to site, it's easy & quick to install & "connect" them together.

Splice Connection

A splice connection must first be inserted in a column or beam in ProtaStructure. A splice connection has been inserted to all columns 1200mm above the 1st storey for this model.

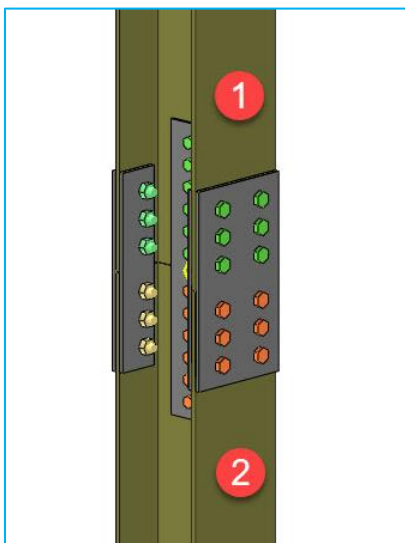
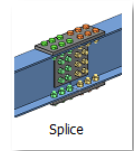

- **Zoom** a column , slightly above Storey 1
- Notice the column is broken into 2 separate elements as a column splice was created in **ProtaStructure**.
- Pick **Splice Connection** under Splice Connections from Macro Gallery
 - 1** – Pick the top column
 - 2** – Pick the bottom column
- The column splice connection is added.
- Press **ESC** to cancel the macro
- Repeat the same for the other columns

- The **green** color bolts are called **Workshop Bolt**. These bolts are pre-installed in the workshop before being brought to the site.
- The **orange** bolts represent the bolts to be assembled on site.

The above setting and other bolt parameters can be viewed and changed in the **Bolt Group property** :

- Double-**click** on any of the bolts → Bolt Group property will appear.
- Go to Settings 2 tab → Assembly Location → two choices are in the dropdown menu :
 - Workshop
 - Site

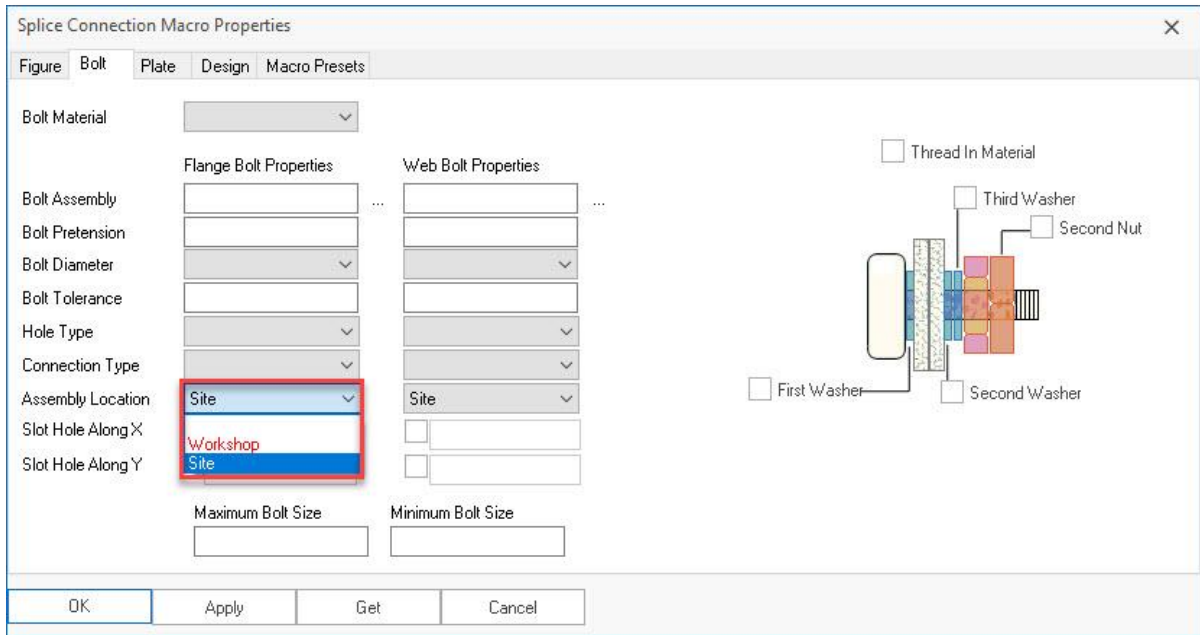

Apex Truss Gusset Connection

We can connect the truss members at the ridge point with the **Apex Truss Gusset Connection Macro**. This macro adds a plate between the members, allowing the members to be welded to the plate. The basic principle when creating a macro is to select the primary members first.

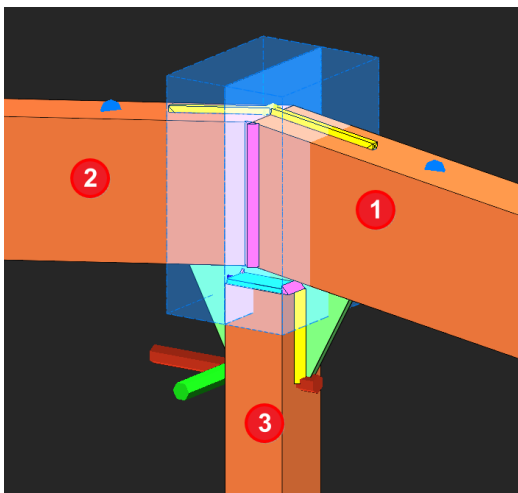
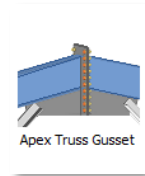

Zoom into the truss ridge point.

- Click on the **Apex Truss Gusset Connection Macro**
- Select the top chord members (**1 and 2**) of truss.
- Select the vertical members (**3**) connected to the ridge.
- Right click on an empty place on the screen as there is no other members to connect.
- Press the **ESC** key to exit the macro.

To increase the width of the gusset plate, let's open the macro properties and change the plate 50 mm right and left.

- **Double-click** the macro icon to open the properties of the connection macro.
- Alternatively, select the gusset plate and press the **"M"** key on the keyboard. Then press the **Enter** key to open the macro properties window.
- In the field shown in the picture, enter the distance of the plate edge as **50 mm** and press the **Apply** button.

- To change the connection design depending on the macro, you can make the necessary changes in the properties window.
- This macro can be created as both welded and bolted.

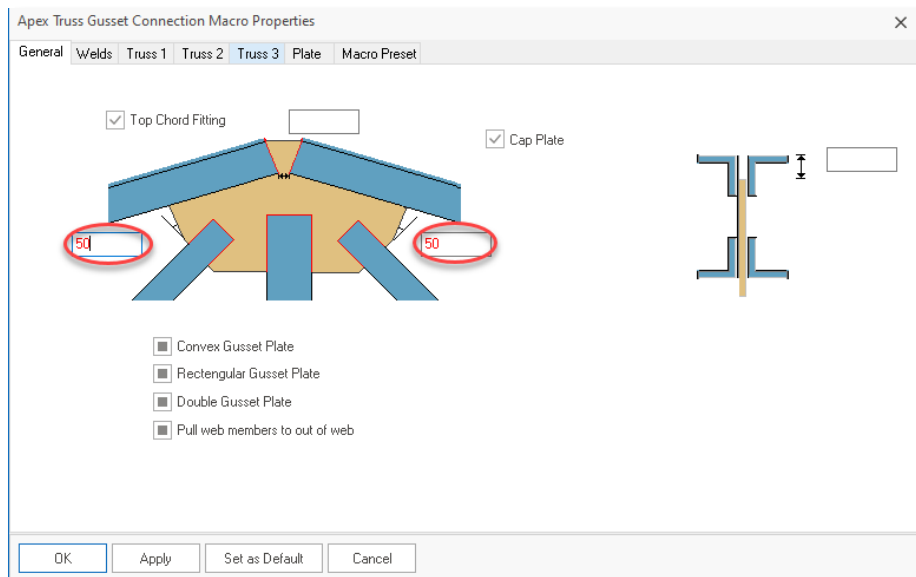

Truss End Plate With Gusset Plate

Truss End Plate with Gusset Plate connection macro connects column and secondary trusses with gusset and endplates. This macro provides a bolted connection to the column flange with an endplate.

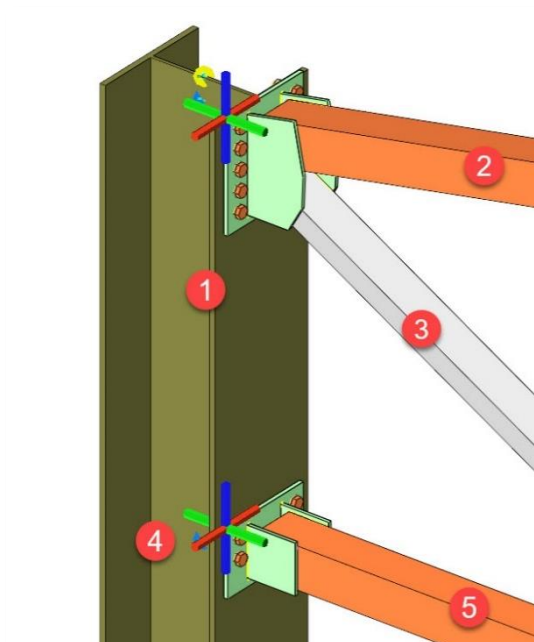
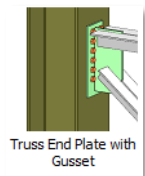

- Pick **Truss End Plate with Gusset Plate** under Truss Connections from Macro Gallery
 - 1** – Pick the main column
 - 2** – Pick the top chord
 - 3** – Pick the diagonal
 - **Right-click** to end and create the connection
 - 4** – Pick the main column
 - 5** – Pick the bottom chord
 - **Right-click** to end & create the connection
- The two connections are created as shown.

Welded Pipe Connection

Welded pipe connection macro can be used to connect tube profiles.

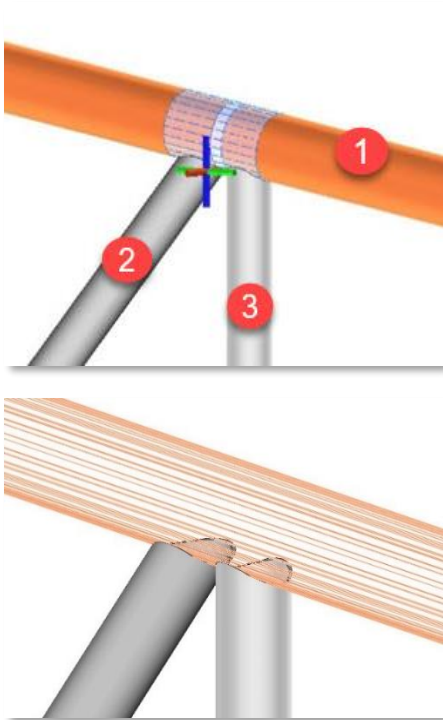
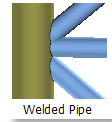

- Click on **Welded Pipe Profile** macro under Truss Connections from Macro Gallery

1 – Select the main top member

2 + 3 – Select the secondary profile, e.g. diagonal and vertical element.

- Right-click** to end and create the connection

Profiles are automatically cut and trimmed around the joint.

When the connection is created, cutting objects will form around the pipe profiles. Secondary profiles should be selected according to cutting priority.

The diagonal and verticals are cut around the primary pipe profile.

Beam to RC Wall/Column Connection

This connection macro creates and designs an embedded steel connection between a steel beam and a concrete wall or column. The steel member must be perpendicular to the reinforced concrete surface. It is essential to have enough space on the concrete surface; else, the macro will not work.

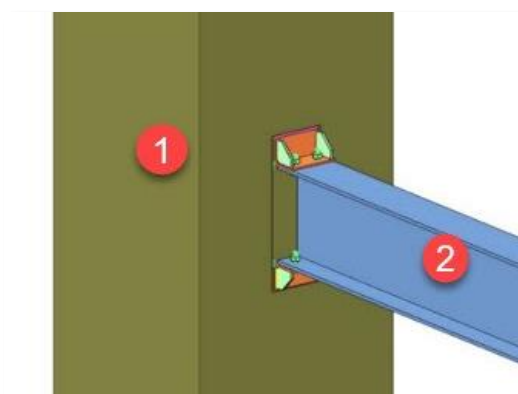

- Click on **Beam to Wall Connection** under Beam to Column Connection from Macro Gallery

1 – Select the concrete wall or column

2 – Select the steel beam

- Right-click** to end and create the connection

Stiffener

In **ProtaSteel**, macros automatically add required stiffeners. If it is desired to add the stiffener to any of the members independently of the macros, or if it is needed while creating a manual connection, the stiffener macro can be used. This macro creates stiffeners at the specified point on the specified profile.

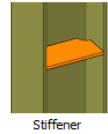

There must be a catchable point in the region where stiffener will be created. If there is no point on the object, we can create a catchable point with point objects or construction line object

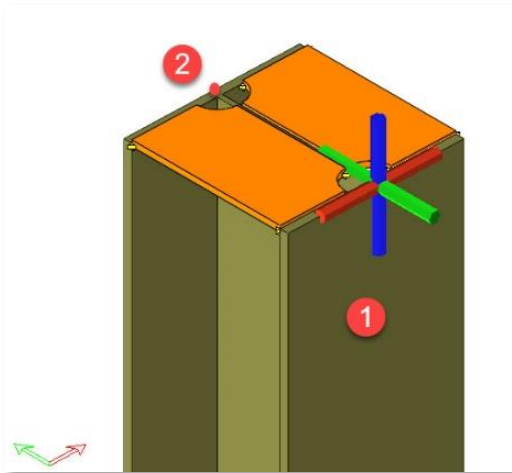

- Click on **Stiffener** under Detailing from Macro Gallery
- 1** – Select a member which want to add a stiffener
- 2** – Select the point on the member

- Click on **Stiffener** under Detailing from Macro Gallery
- 1** – Select a profile which want to add a stiffener
- 2** – Go to a point on the profile.
- 3** – Press **ENTER** and write **“dz-100”**
- 4** – Press **ENTER**
- The stiffener is created as shown below.

We can also use the **“dx.”**, **“dy.”**, **“dz.”** command to distance.

To create a stiffener at any point on the profile, press the **CTRL** key and left click on any snapped point on the profile.

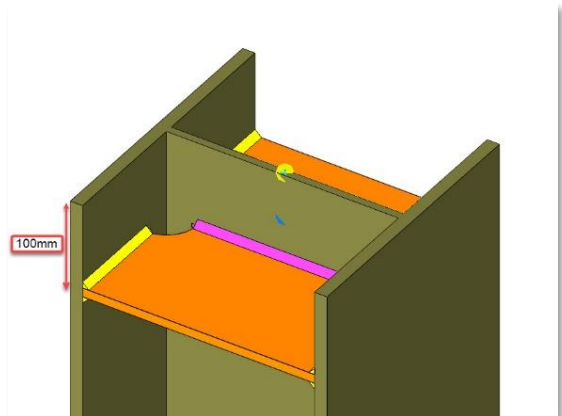
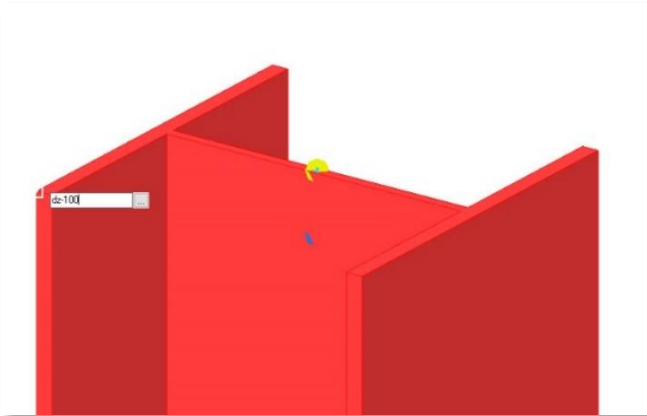

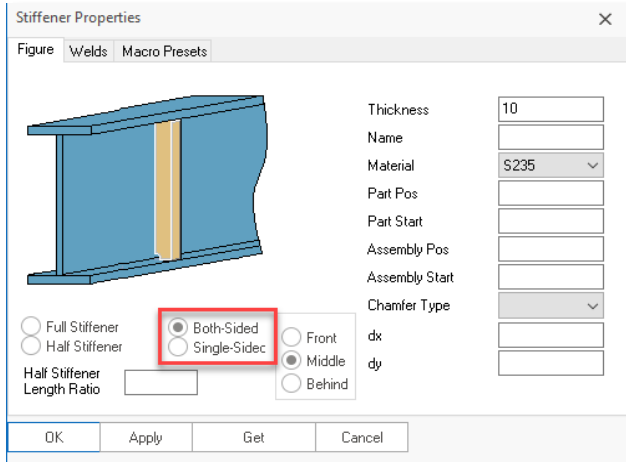

Stiffeners can be placed on both sides of the profile or one side. You can change these options on the macro properties.

The **out-of-plane** movement of the stiffeners can be changed with the **front-middle-back** commands. **CTRL+W** key combination can use to change the out-of-the-plane direction. You can select all members of the macro connection with the **CTRL+M** key combination.

Insert Sag Rods

In **ProtaStructure**, the main steel members are modelled and designed, usually omitting the minor or non-structural members to keep the model size manageable and efficient. After the model is transferred to **ProtaSteel**, you might want to add ancillary steel members such as sag rods.

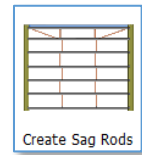

We will insert some sag rods between the girts along axis 3 :

- Double-click on **3D view** in the Explorer pane to go to the default 3D view
- Right-click on **Create Sag Rod** icon under **Purlin and Girt Connection** from Macro Gallery → This will expose the Sag Rod Macro Dialog.
- Key-in the offsets 50 mm and Number of Intervals = 3 (as shown below)
- **Untick** the diagonal so that it will not be included
- Choose the **section profile** by clicking on “...” (as shown above) → Pick Round Bar D10 → **Select**
- Pick **Get** to make these input the default from now on → **OK**

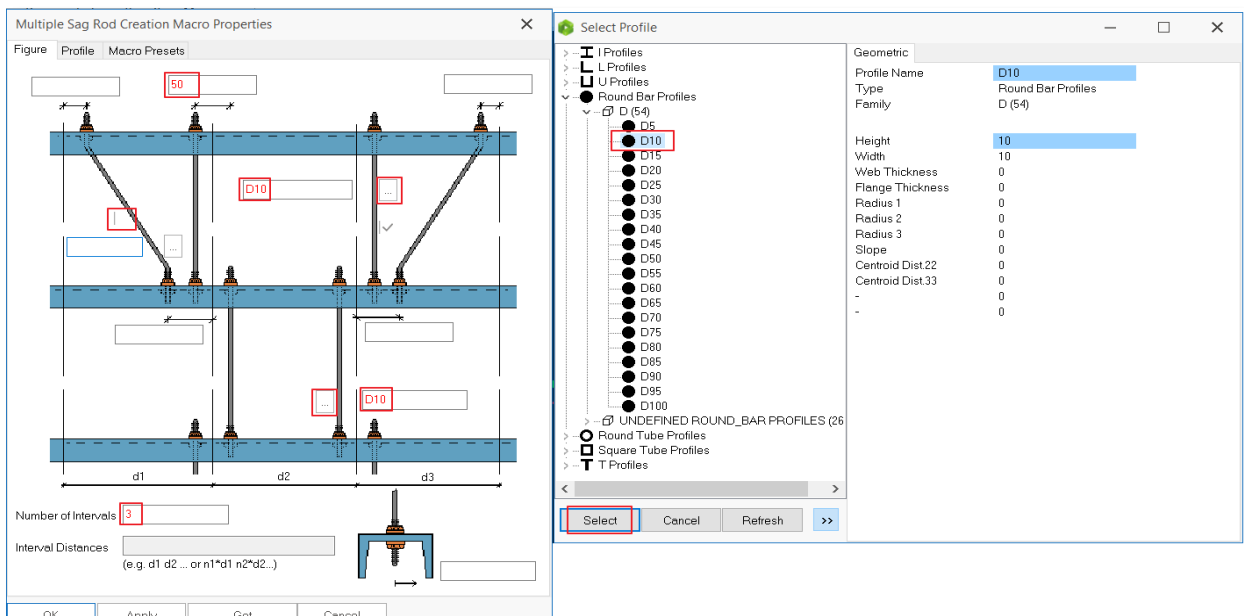

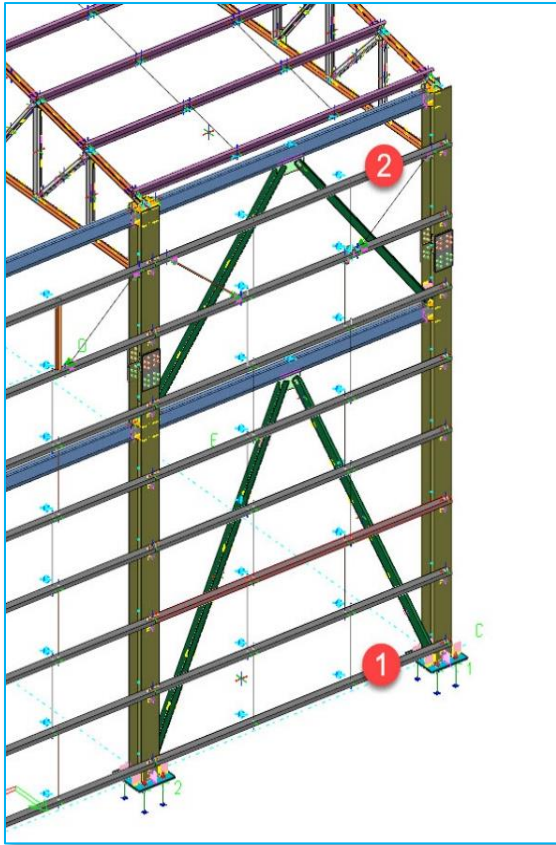

- Left click on the Sag Rod icon
- Notice the cursor turn to a hand icon  meaning that it is waiting for required element selection action(s).

1 – Left-click on bottommost girt

2 – Left-click on topmost girt

- Right-click → Sag Rods will be inserted

Insert sag rods for another panel between grid B, C & D using the same steps above, i.e. start by picking the bottommost girt (no need to pick the sag rod icon again)

- Once complete, press **ESC** to cancel the Sag Rod macro action.

Notice the cursor changes back to default arrow .

Each sag rod has its individual properties and can be selected, deleted, or changed.

Double-clicking it will reveal its properties.

All the sag rods are represented by the macro sign  They can be changed in a group by selecting this macro sign → press **“Enter”** as stated previously.

You can use **Sag Rod Connection** or **Sag Rod Holes** macros to connect to sag rods and girts/purlins.

Sag Rod Holes

In **ProtaSteel**, **“Sagrod Hole Macro”** is used to drill holes on the members to connect the sag rod. This macro is located in the **“Purlin and Girt Connections”** menu in the macro library.



Macro default settings can change before adding the macros. Left click on the **“Sag Rod Hole”** icon to change the macro presets.

1 – Left-click on the **“Sag Rod Hole”** icon

2 – Select purlin or girt member

Holes will be opened on the member at the points where the sag rod connected.

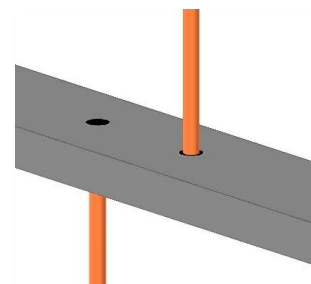

Select the hole and hit **M + ENTER** keys on the keyboard to open macro properties. Macro default settings are set to **“by working points”**. This setting represents the points where the sag-rod connected.

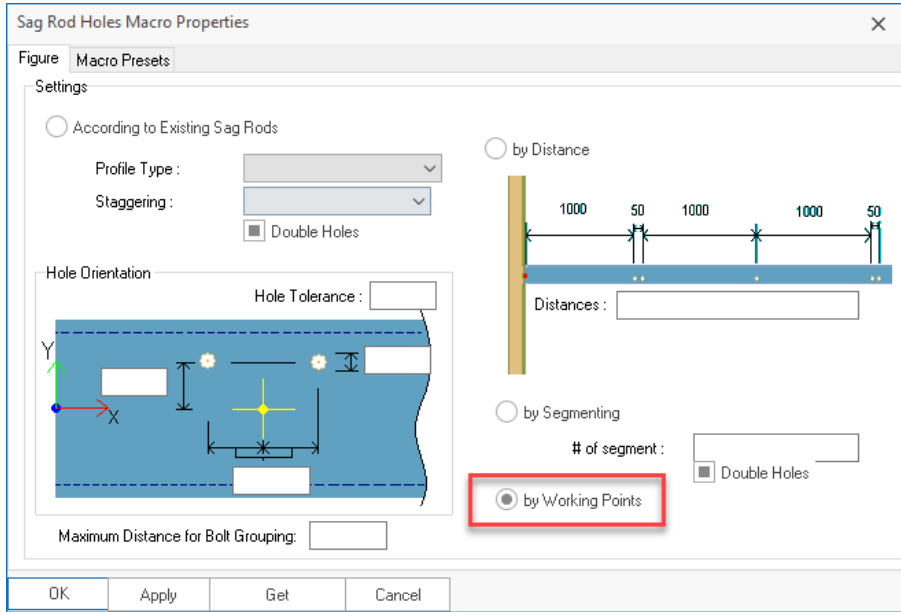

Sag rod holes can be created on members other than purlins and girts. In the macro library, right-clicking on the sag rod hole macro opens the macro properties window to create sag rod holes in different members. **“According to the existing sag rods”** option is enabled, and the profile type is selected.

For example, let’s select **“beam”**

- On the hole orientation layout, select the hole diameter is **14mm**, the hole tolerance is **2mm** (total hole diameter 16 mm is drawn).
- Set the hole’s distance to the profile centre line as **50 mm** and the horizontal distance between the holes as **200 mm**.
- Then check the **“Get”** option. Thus, we have changed the default settings of the macro.

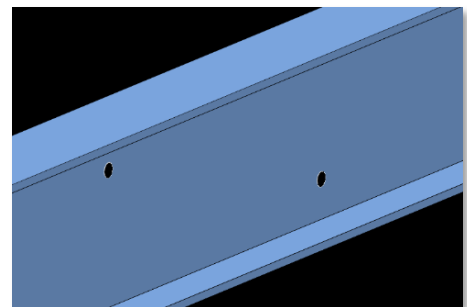
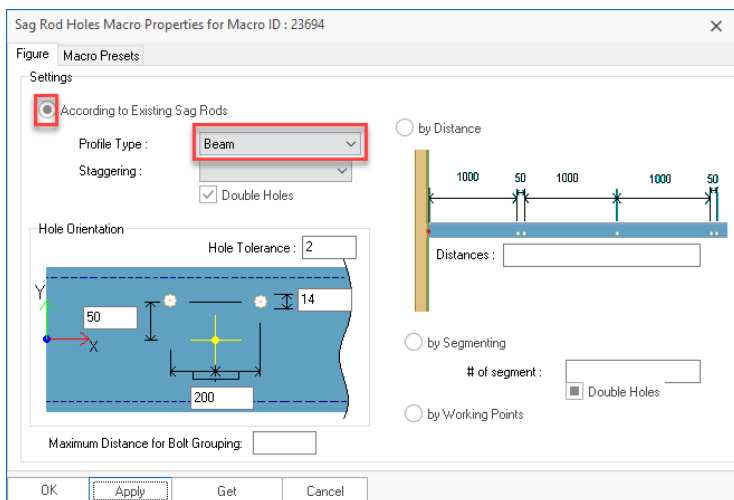

To create more than one hole group, the operation can be done by entering the distance or the number of groups.

For example,

- After the hole settings are made for a group on a beam, select the **“by segmenting”** option.
- Write **“10”** in **“#of the segment”**.

Thus, ten holes are drilled at equal intervals.

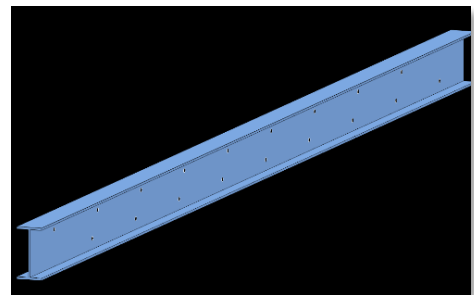
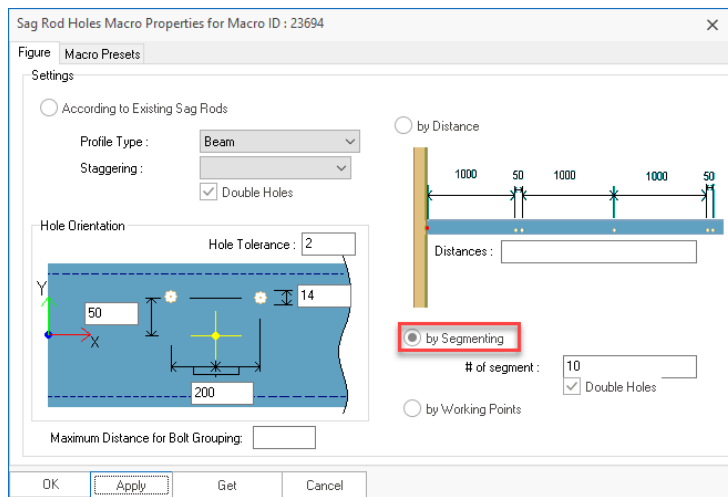

Sag Rod Connection

In ProtaSteel, **“sag rod connection macro”** can also be used to drill holes for the connections of the sag rods connected to purlins and girts.

This macro can be used for the connections of the sag rod members connected vertically and diagonal to purlins and girts.

Different connection types can be applied by changing the macro properties.

Different types of connections are shown below.

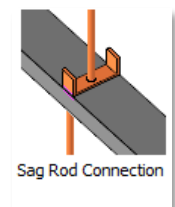

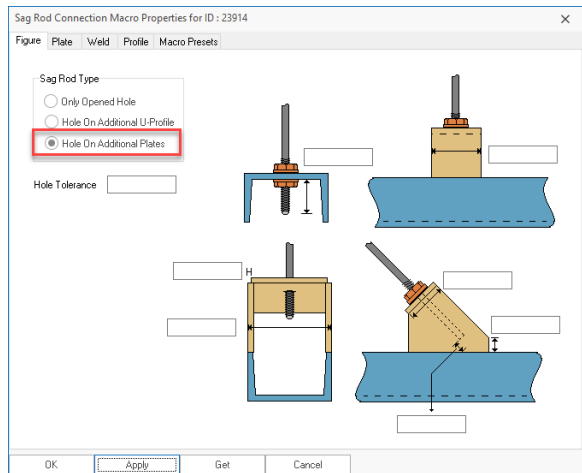
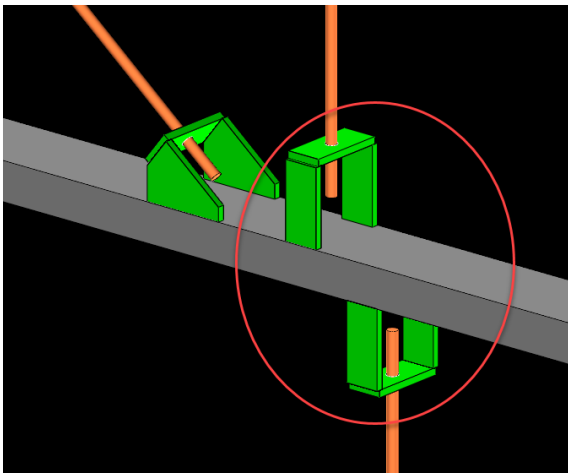
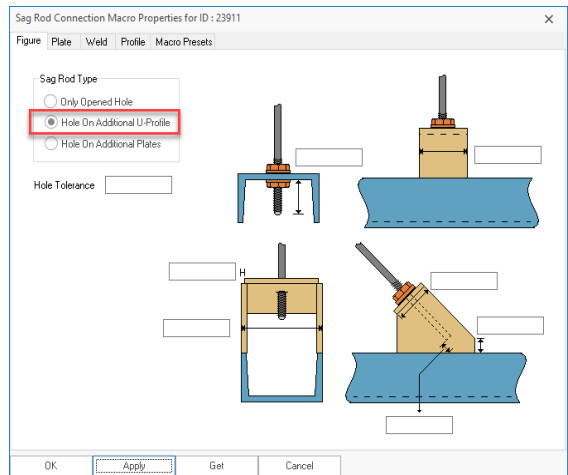
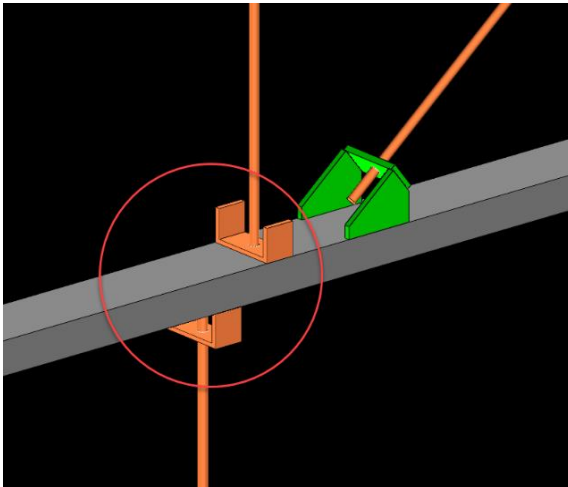
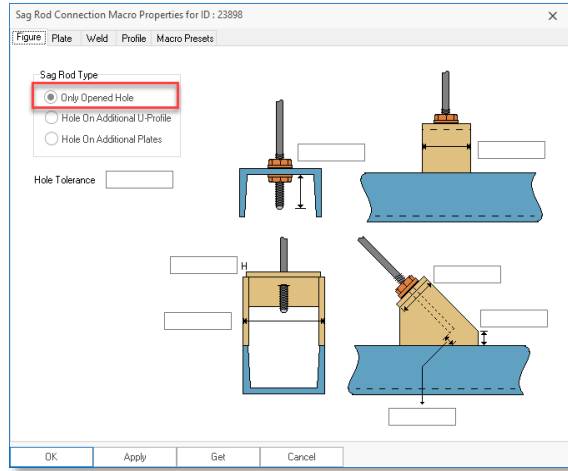
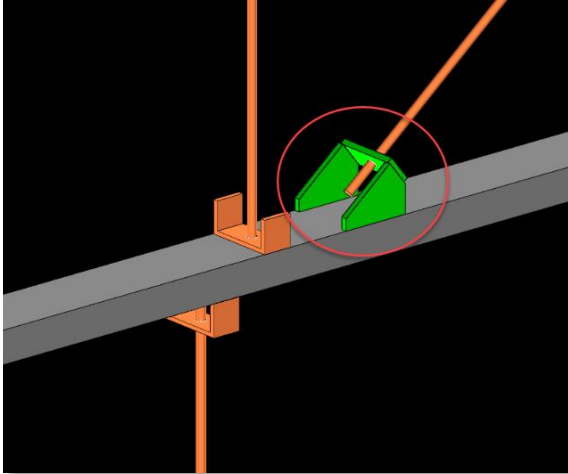

IntelliConnect For Fully Automated Steel Connection Design

IntelliConnect automatically assesses joints to your preferences and creates and designs steel connections in batches. It covers a wide range of simple, moment, splice, and weld connections. It considers constructability by intelligently arranging and configuring all the components of the connections without user intervention. This results in a vast improvement in productivity as it minimizes the time required to create & correct these connections manually.

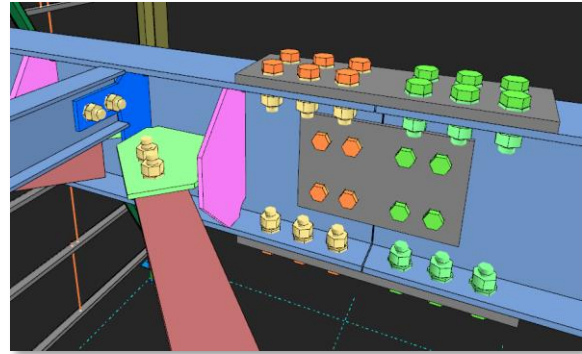
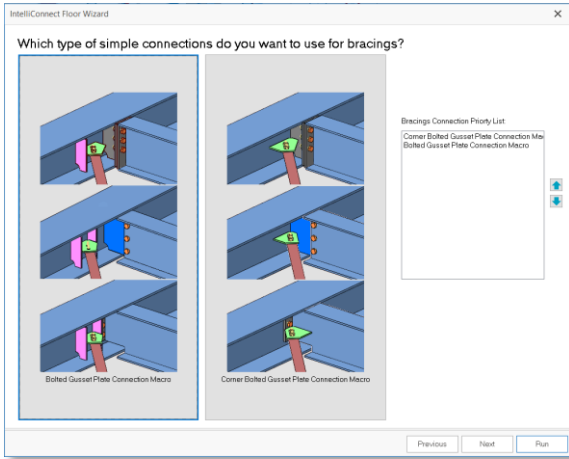

Why use IntelliConnect?

Steel detailing software typically creates connections automatically between two elements by applying specific rules, i.e., **“Rule-based joints”**. These rules usually include names of the profiles, moment releases or lack thereof, the loads in the elements, and approach conditions (whether the secondary is approaching the main from the flange or the web).

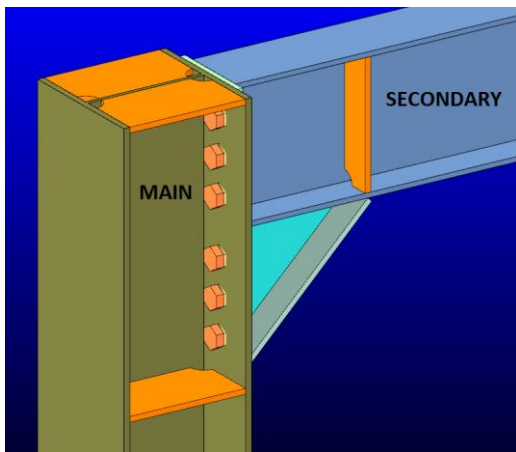

Figure 1

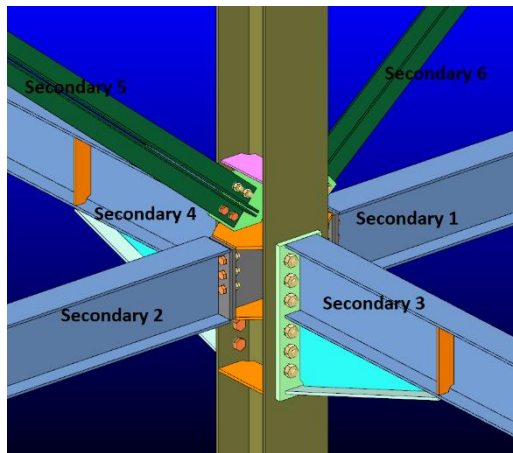
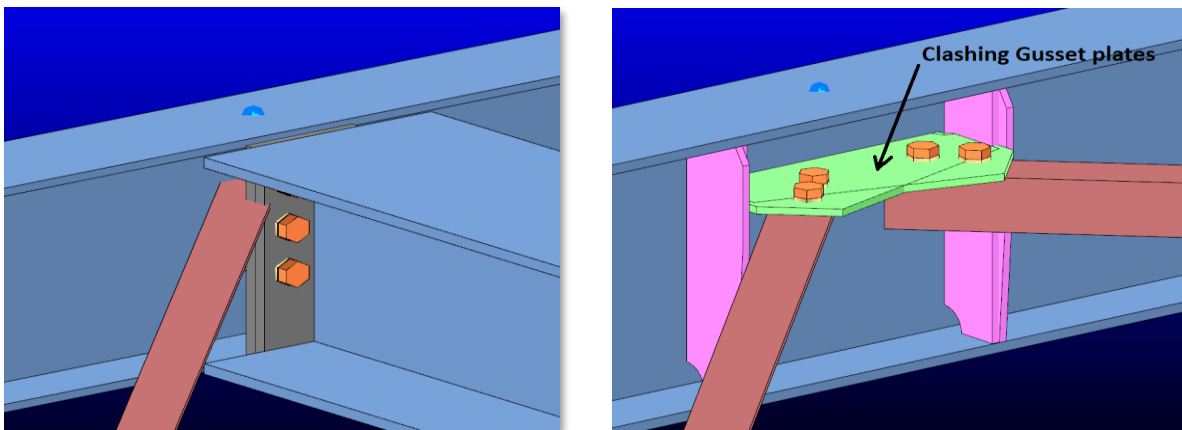

Figure 2

While **“Rule-based joints”** are beneficial in simple cases where the main and the secondary (incoming profile) are the only two profiles present at a joint (see Figure 1 above), they fail to deliver for complex joints when more than two elements meet at the same joint (see Figure 2) :

- Applying a blind “Rule-based joint” would create many clashes for complex joints, resulting in wasted & unproductive time in manual amendments.
- “Rule-based joints” will not have the intelligence to “auto-shift” the secondary member slightly to facilitate a connection. Such requirements are commonplace in steel detailing when incoming members need to be shifted slightly to avoid clashes and make erection possible.
- A typical example (see Figure 3) would be the need to shift the horizontal bracing in flooring systems away from the beam-beam intersection points to avoid clashes with the connection plate.
- “Rule-based Joints” typically do not combine incoming elements to create a single shared connection if the situation demands it.

For example (in figure below), two horizontal braces will connect to the same point separately, creating a clash between the gusset plates rather than using a single shared gusset plate.



IntelliConnect is an advanced technology that attempts to address issues common in building detailing. IntelliConnect automatically determines which connection type is more appropriate for the selected profiles by checking their type, location, and orientation. If necessary, it automatically alters connection parameters and creates a more feasible & practical connection.

IntelliConnect Scope

IntelliConnect can automatically create connections for various types of elements and profiles. IntelliConnect can provide a solution for 36 different cases grouped in 9 categories. These categories can be listed as follows:

- Splice connections
- Batten plate connections
- Sag rod connections
- Vertical bracing connections

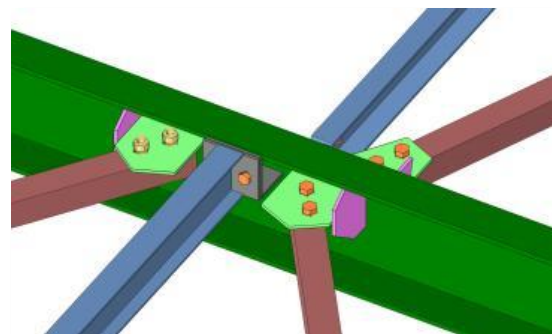

- Truss connections
- Purlin and girt connections
- Floor beam connections (with horizontal bracing connections if there are any)
- Beam-Column connections (with horizontal and vertical bracings if there are any)
- Base plate connections (with vertical bracings if there are any)

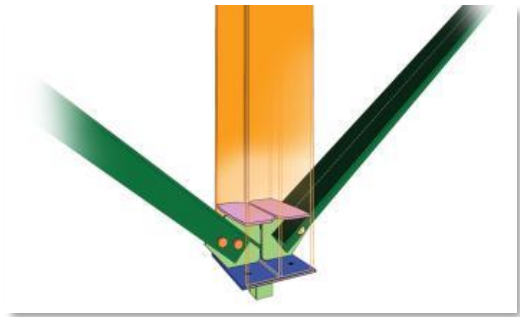

These include “**simple cases**,” e.g., where there are only two primary elements, and “**complex cases**” where more elements meet at the same node.

Cases Covered

The following “**Simple Cases**” are covered by IntelliConnect :

1. Splice connection (Supports whatever profiles are supported by the Splice macro)
2. Column Base Plate with no incoming vertical bracing. (The column needs to be an I section)
3. A single beam framing into a main beam. The Beams can be I or channel profiles. The type of beam to beam connection can be the following 1) The Stiffened end plate connection. 2) The Fin plate connection 3) The beam to beam end plate connection.
4. A single beam framing into a column. The profiles may be I or channel profiles. The type of beam to beam connection can be the following 1) The Stiffened end plate connection. 2) The Fin plate connection 3) The beam to beam end plate connection.
5. A single horizontal brace framing into a beam. The horizontal brace may be any profile supported by the Bolted gusset or welded gusset macros)
6. A single vertical brace framing into a column. The vertical brace may be any profile supported by the bolted or welded gusset macros.
7. A single purlin sitting on a beam or truss element. The type of connection may be any connection supported by the Purlin/Girt macro
8. A single girt framing into a column. The type of connection may be any connection supported by the Purlin/Girt macro
9. Creation of batten plates on twin profiles.
10. Connection of a single purlin passing continuously over a truss top chord or roof beam.

IntelliConnect covers the following “**complex**” cases:

1. Two horizontal braces framing into a beam (from any side – web or flange)
2. Two vertical braces framing into a column (from any side – web or flange)
3. Truss connecting with more than one truss secondary framing into the truss top or bottom chord.
4. Two purlins sitting on a truss top chord or a roof beam
5. Two girts framing into a column (either colinear or one from each orthogonal direction)
6. Two floor beams framing into a main beam from opposite sides
7. Combinations of floor beams and horizontal braces framing into each other at the same point from both sides
8. Up to 4 beams framing into a column (two from the flange side and two from the web side)
9. Combination of beams and vertical braces framing into a column

As far as limitations on profile types and connection types are concerned, the same restrictions apply in simple cases.

How to use

The following is the summary of how to use *IntelliConnect* :

- The user will first select single or multiple nodes that hold all elements that meet at a single point.
- After that, the user right-clicks and goes into the **IntelliConnect** context-sensitive menu and selects the type of connections to create.
- For some **IntelliConnect** connections, however, the user needs to select frames and not nodes (e.g., simple cases 9 and 10 stated previously)
- **IntelliConnect** will use its “internal classifying algorithm” to connect as many of the nodes selected by the user as possible.
- However, if it encounters an unsupported case, it will either partially connect the node or leave it completely unconnected.
- A detailed report will automatically be displayed listing nodes that are successfully connected or failed to connect.
- **IntelliConnect Node Control** tool is an interactive navigator to browse & examine points that are partially connected or not connected; so the user can connect/correct them manually.

Truss Example

- Select the nodes (joints) of the steel structure where you wish to create a connection
 - Joints are shown as blue dots at the end of the member. You can click and drag a box to select all members and the nodes for simplicity.
 - We will create the truss connections based on the Quick Start Guide Steel model for illustration purposes.
- Go to the **3D view**
- Select all the truss members by dragging a box around them

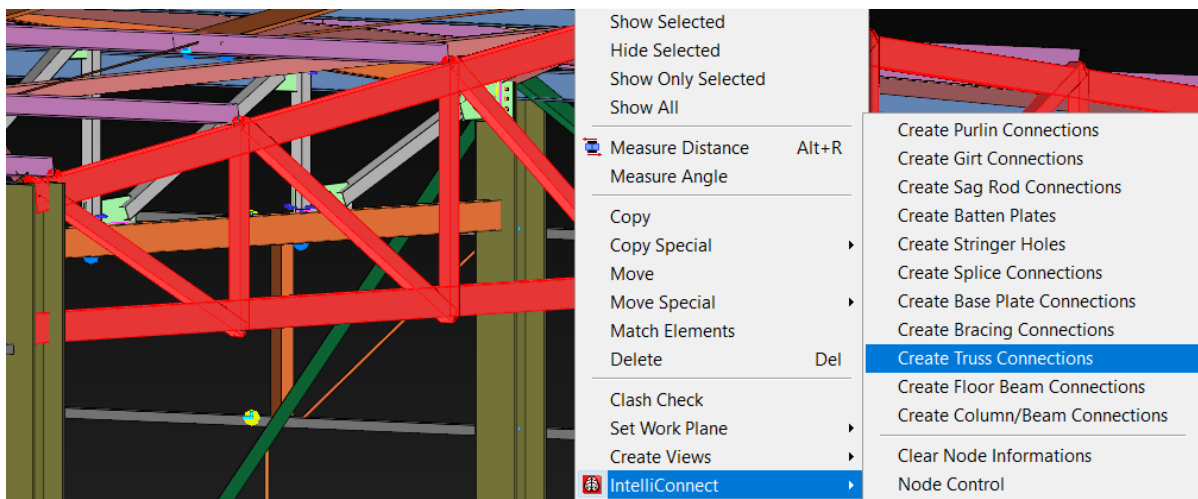

- Right-click → IntelliConnect → Pick Create Truss Connections
- Type in the preferred Gusset Plate Thickness in the Truss Wizard or leave it blank if you want IntelliConnect to select thickness for you.

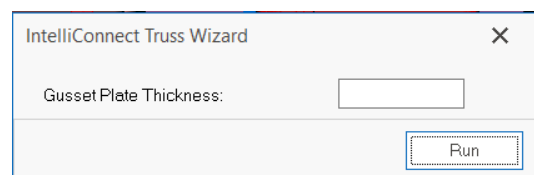
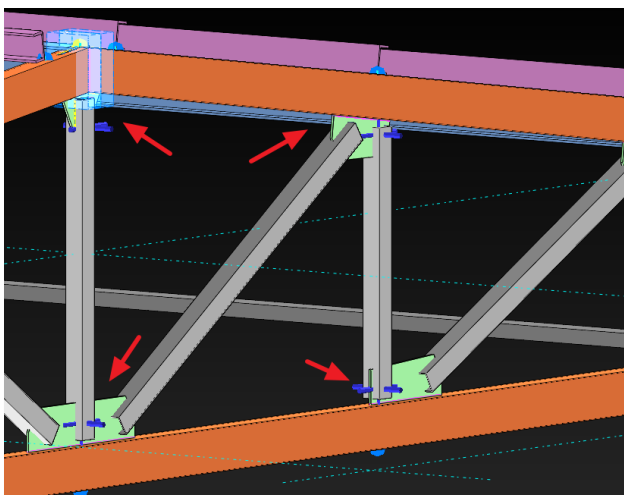

Purlin Example

- Select the nodes (joints) of the steel structure where you wish to create a connection
 - Joints are shown as blue dots at the end of the member. You can click and drag a box to select all members and select the nodes for simplicity.
 - We will create the purlin connections based on the Quick Start Guide Steel model for illustration purposes.
- Go to the **3D view**
- Select all the truss members and purlins by dragging a box around them

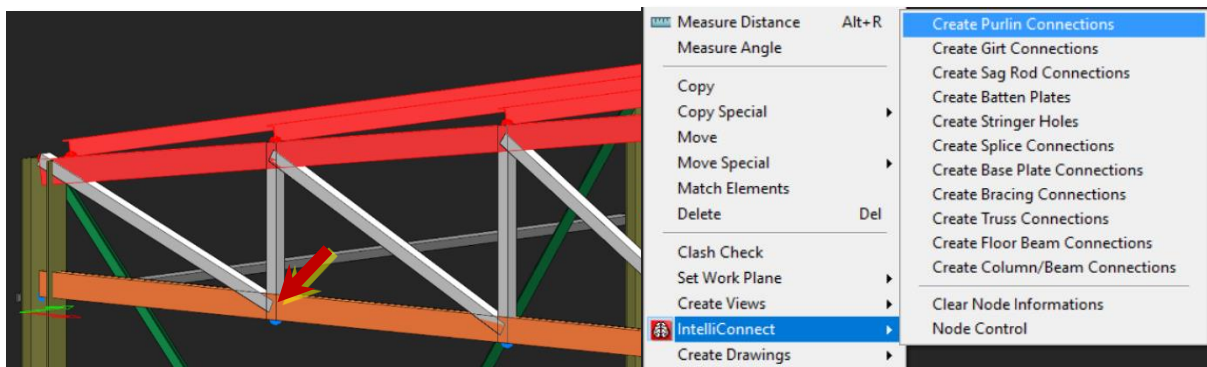

- Right-click → IntelliConnect → Pick **Create Purlin Connection**

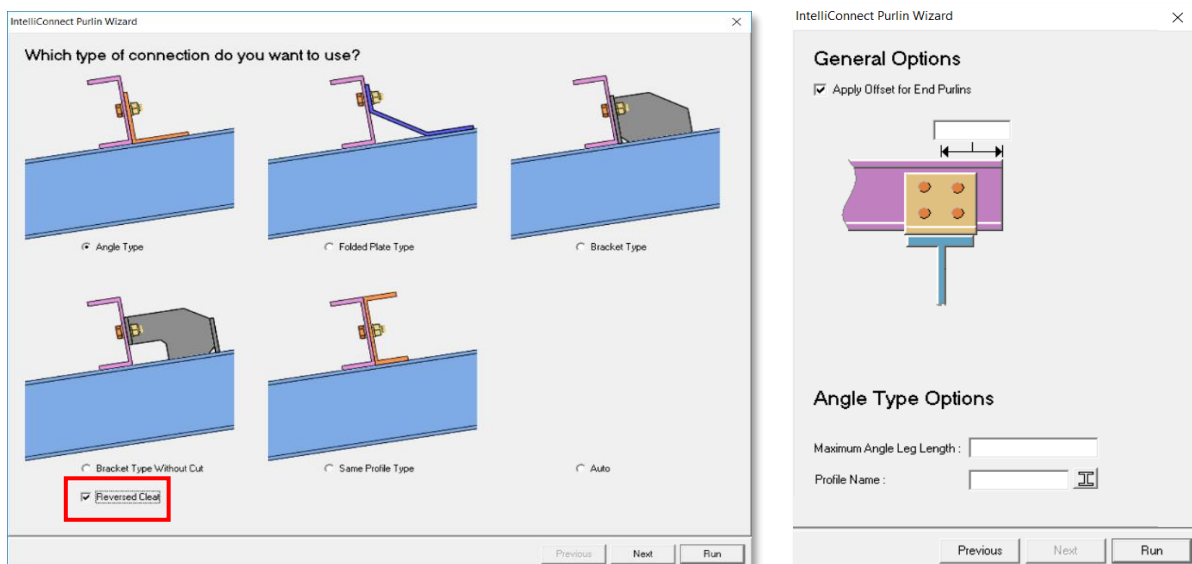

- In the Purlin Wizard, choose the preferred type of connection
- For this example, select **“Angle Type”** & **“Reversed Cleat.”**
- Input further parameters in the following wizard dialog → **Run**
- Max Angle Leg Length or profile can be specified

- **AutoConnectLog** text file will open → Review its contents as it lists all the connections that are successfully / unsuccessfully created

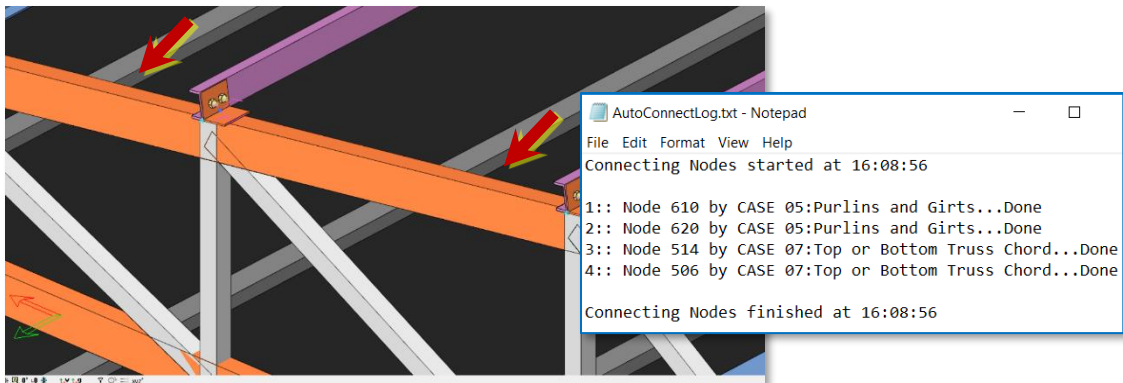

Beam-Column-Brace Example

We will auto-create a beam-column-brace connection for illustration purposes based on the Quick Start Guide Steel model.

- Go to **Storey 1 view** → Select all the column and beam joints along axis 2

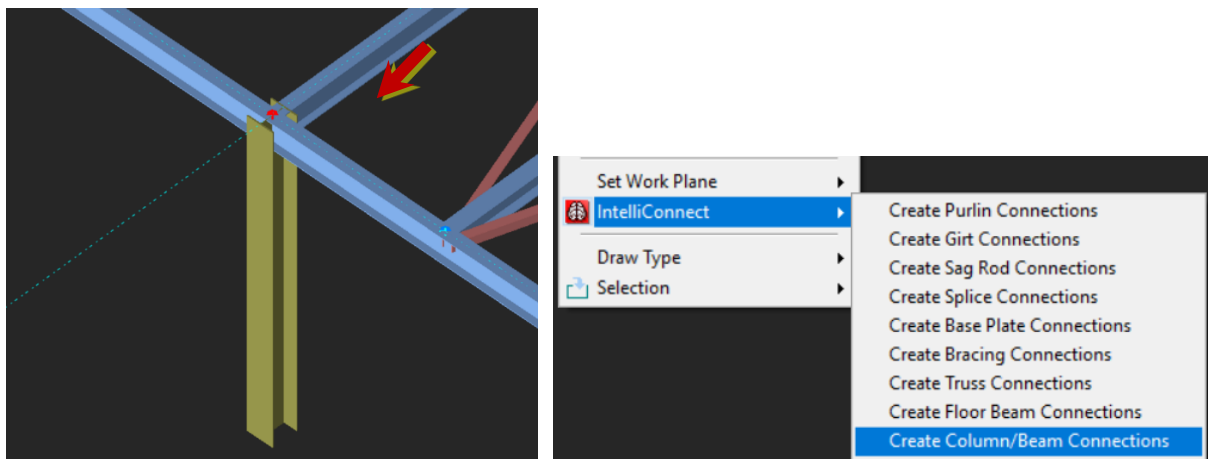

- **Right-click** → **IntelliConnect** → **Pick Create Column/Beam Connection**

If there is more than one possible connection configuration, the following dialog allows you to choose which connection type to consider and its priority.

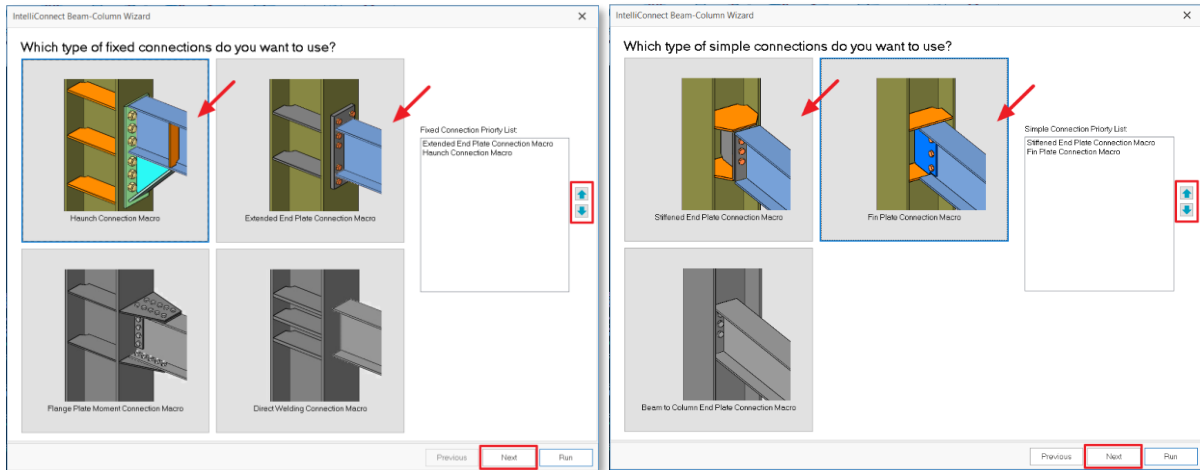

- Pick the connection types to consider → Adjust the priority using up/down arrow → **Next**
The relevant bracing shifting, bracing connection & haunch connecting settings will appear next
- Make desired adjustment → **Run** → Then connections will be created

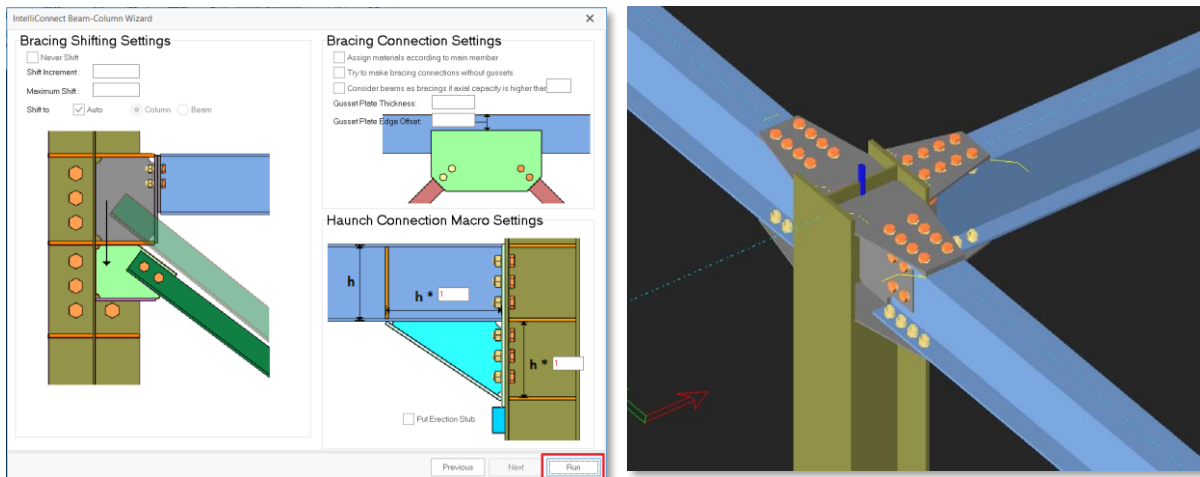

Beam – Beam – Brace Example

We will auto-create a beam-beam-brace connection based on the Quick Start Guide Steel model for illustration purposes.

- Go to **Storey 1 view** → Select all the beam and beam joints along axis 2

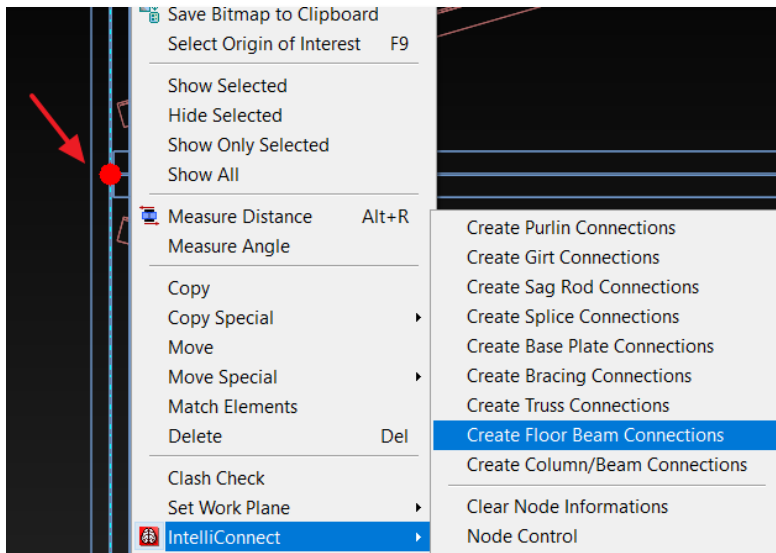

- Right-click → IntelliConnect → Pick Create Floor Beam Connection

When there is more than one possible connection configuration, the following dialog allows you to choose which connection type to consider and its priority.

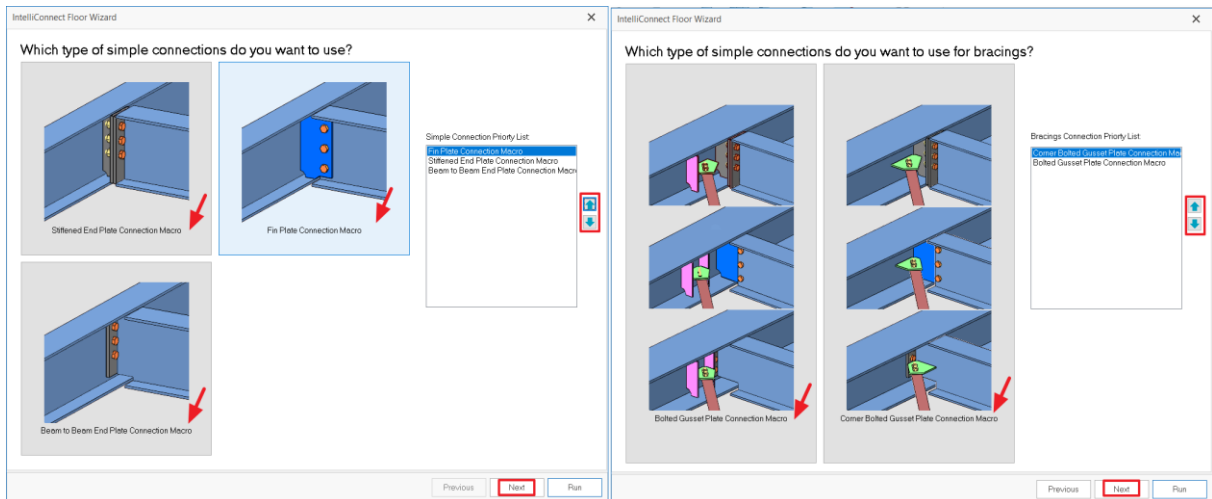

- Pick the connection types to consider → Adjust the priority using up/down arrow → **Next**
The relevant bracing shifting, bracing connection settings will appear next
- Make desired adjustment → **Run** → Then connections will be created

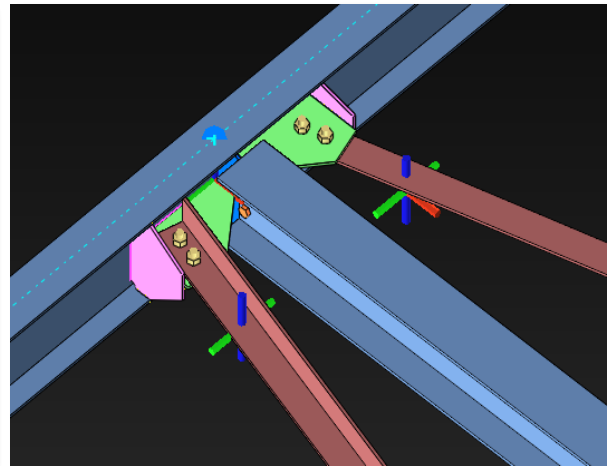
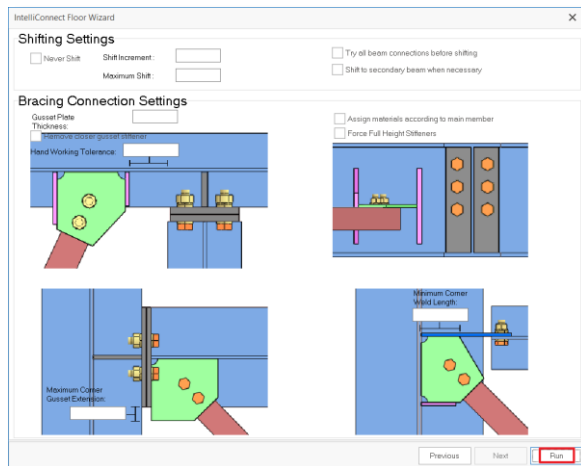

- ❖ Floor Beam Connections (IntelliConnect) works when beam to beam connection is hinged in ProtaStructure.
- ❖ Change to “Line Mode” (ALT+D) → Green Dot shows hinged connection.

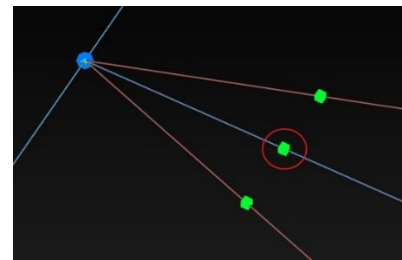

IntelliConnect and Connection Ordering

Although detailing order often depends on the structure itself, it is usually better to start from large connections to small ones. The connection order depends on the size and shape of the structure. For example, for the high-rise buildings, beginning the connection process from the bottom is more practical. Most structures will have similar, symmetrical, or identical axes. Whether you use IntelliConnect, finishing the frame connections first is a good practice.

In a typical warehouse structure with a truss, the recommended connection order is given below :

- Splice connections (Columns, Beams and Truss members)
- Truss connections
- Apex connections
- Truss top and bottom chord connections to columns
- Base plate connections
- Manual (User-defined) connections (User-defined connections can be saved for later use and repeatedly used for similar joints)
- Connections of the compression members located between the column or truss system.
- Vertical and roof bracing connections
- Purlin or girt connections
- Sag Rod Connections
- Batten Plate Connections

For building type multi-story structures, the recommended order to use IntelliConnect is given below;

- Splice Connections
- Beam-to-column connections (Moment connections first)
- Beam-to-Beam connections
- Horizontal bracing connections
- Base Plate Connections
- Vertical bracing connections
- Purlin, sag rods, and batten plate connections

When working with IntelliConnect, it may be necessary to change the order for two reasons:

- The IntelliConnect operates on a joint. All connections on this joint are simultaneously considered. For instance, in the case of column-beam connection (beams connecting to both sides of the column) with vertical bracing, IntelliConnect will create all connections simultaneously to prevent clashing by using shared parts. That will change the detailing order.
- Since IntelliConnect operates on a joint, it is unclear whether the other joints are too close or too far away. If the members or joints are close enough to collide with each other, IntelliConnect may face conflict problems. In this case, the **Clash Check** command can detect collisions. IntelliConnect can run with the user's requested order so that it does not use the connection information of other joints.

In summary, connection design should be initiated from the primary connections. IntelliConnect can be triggered on a grid or story basis. The girt, purlin, and sag rod connections can follow. Batten plate connections should be created finally.

Manual Connection (Info Only)

In ProtaSteel, users can create connections manually and save them in the macro library to reuse them at similar nodes. A steel beam to RC column manual connection will be demonstrated below.

Steel Beam to RC Column Manual Connection

Steel beam to reinforced concrete column connection can be done using manual embedded steel plate connection in ProtaSteel.

The following example illustrates the steps of creating an embedded steel plate connection.

1. Firstly, we can cut off excessive steel beam using the **Object Cut** command (in **Edit** tab)
 - I. First, select Member to Cut.
 - II. Second, select the Cutting Member.
 - III. Select "No" from the pop-out warning to remain the Cutting Member.

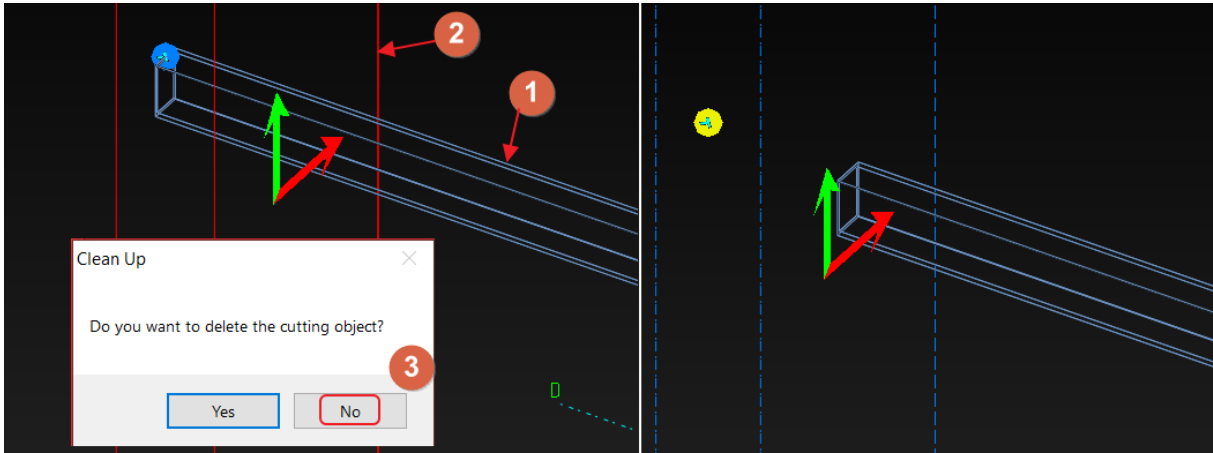

Remember to turn off the “Cut” in Visibility Filter when necessary.

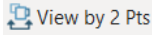
2. Create the section view plane with the command **By Two Points**  by accessed from the **View** tab → **View By 2 Points**
 - Pick a point between the end of the steel beam and the surface of the concrete.
 - Double click on the background to open the **View Properties** → save View Name: **Cut Section A** or any preferred name. (Refer to **chapter 7 – Creating new Views**)

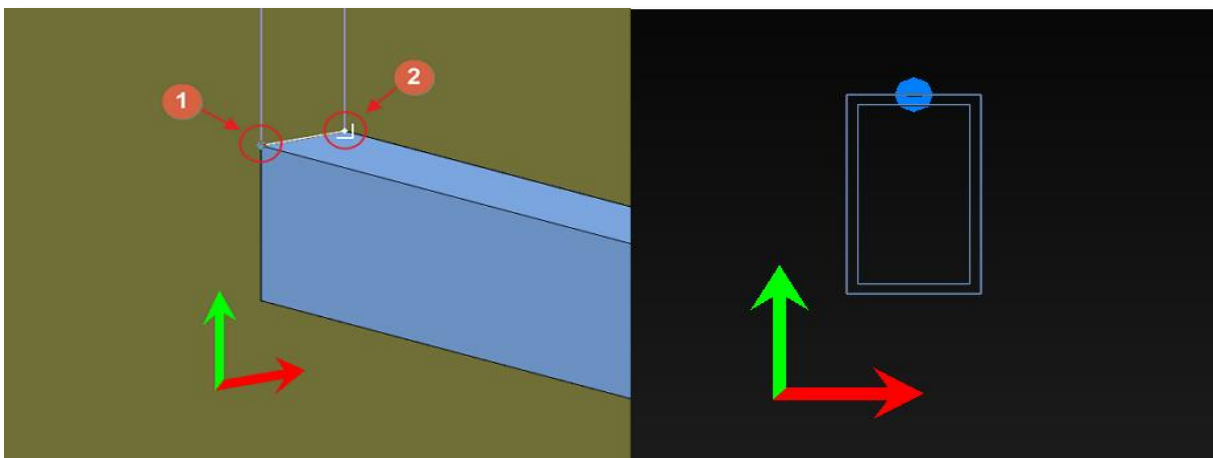

3. In the **Cut Section A View**, navigate to the **Views** tab → **select To View Plane**. This sets an active work plane based on the current view.

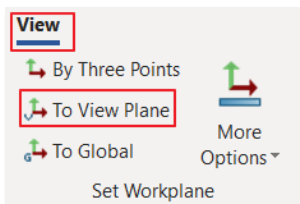

4. Select the **plate** command (in the **Steel** tab) and select the four corners of the steel beam clockwise → A plate will be created. Then right-click on the beam and select **Hide Selected**.

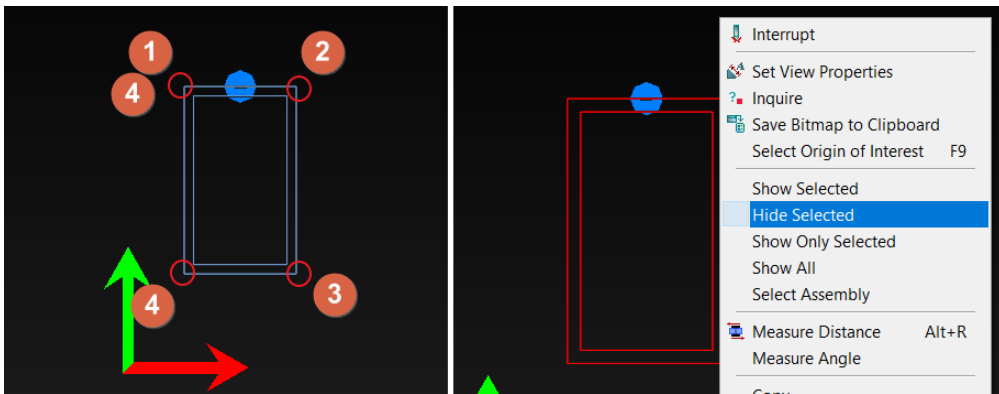

5. Use **ALT** to select each corner and **Right-click** > **Move Special** → **Linear** to move each corner accordingly.

- Left Top Corner – X: -30, Y: 50
- Right Top Corner – X: 30, Y: 50
- Right Bottom Corner – X: 30, Y: -50
- Left Bottom Corner – X: -30, Y: -50

Directions x, y, z must always check based on the workplane (axis direction icon ) shown in the modelling view. The axis can be based on colour: **Red = x**, **Green = y**, **Blue = z**.

Then, right-click in the background to **Show All**.

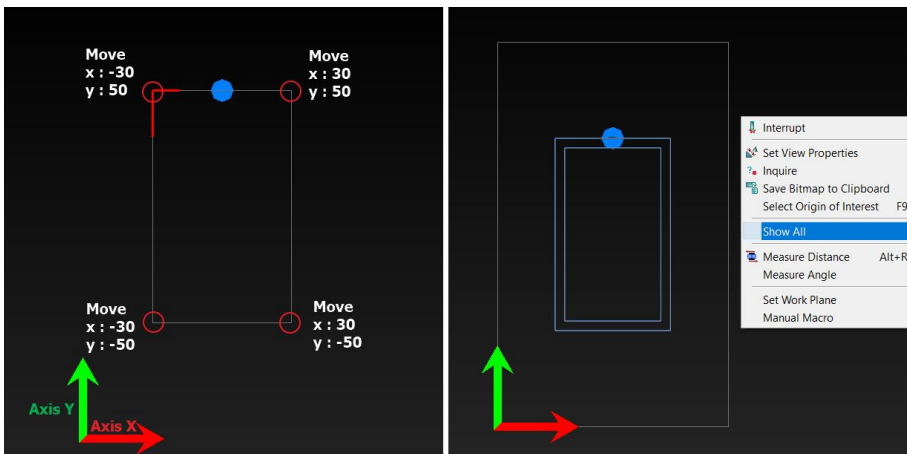



6. Right-click on the plate, set:

- Position In Depth: **“Behind”**
(Alternatively, can be adjusted via hotkey **CTRL+W** in modelling view)
- Thickness (t): 10

7. Go to **3D views**, remove the overlapping concrete using the Object Cut command.

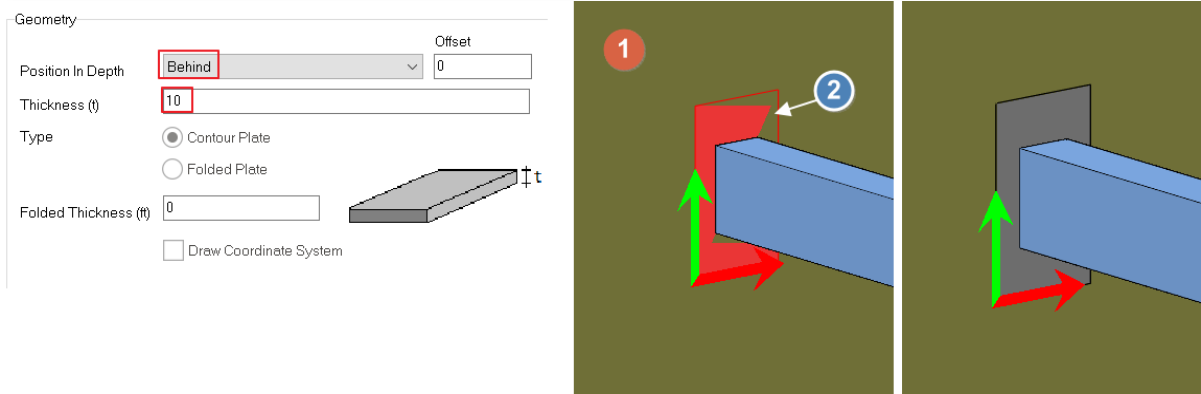
- First, select the concrete member.
- Second, select the steel plate.
- Select “No” from the pop-out warning to remain the Cutting Member.



8. Go to the **Section Elevation View** and go to **Edit** tab → **Point** → hold **Shift** key + **left click** on “**Dividing Points**”  command to set to “4” in **Number of Points?** and press **OK**.

Left click on the command to start creating reference points.

- **Step 1** - start at the left top corner of the steel plate and end at the left bottom corner of the plate.
- **Step 2** - start at the first point created from the top corner of the plate, drag horizontally and end at the right side of the steel plate.
- **Step 3** - Repeat **step 2** but start at the Fourth node, created at **step 1** instead.
- Delete all points created in **Step 1**. Delete 2nd and 3rd nodes created in **Step 1** and **Step 2**

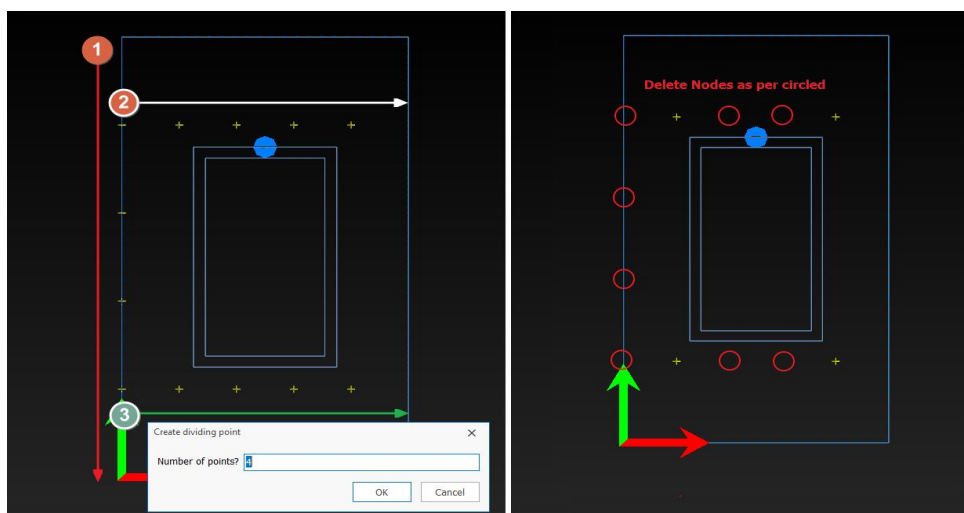

9. After finished creating the reference points, we can now create steel studs. Hold **Shift + Left click** on **joist** (in **Steel** tab) to access the **Default Joist Setting** and set:

- Profile name: **D10**
- Out of plane: **Middle**

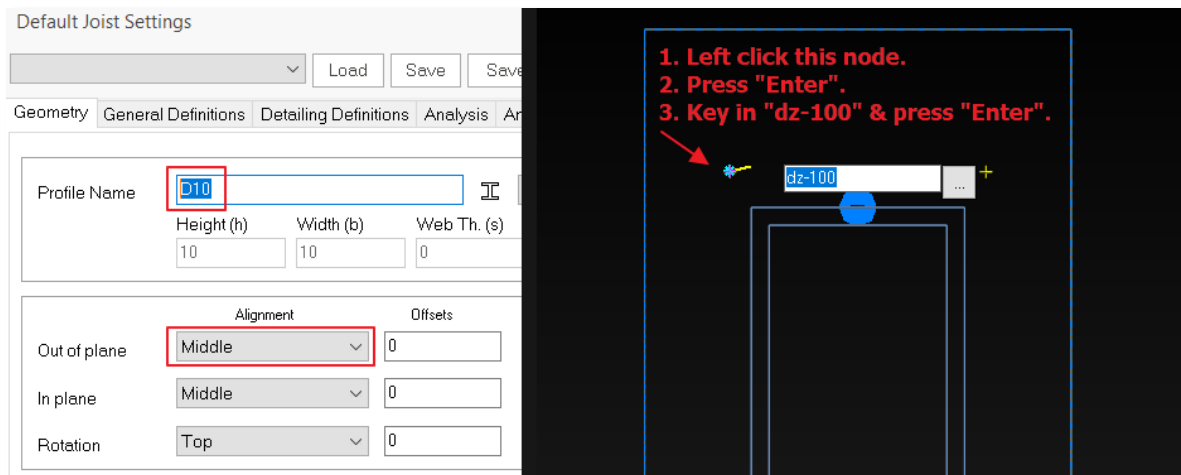

10. Left-click on the reference point at the left top corner to start creating the rebar → press **Enter** → key in "dz-100" and press **Enter** again.

Then, go to the **3D view** with **wireframe view mode**, move the stud by -10 on axis Z to avoid overlapping with the steel plate

(Always remember to check your current workplane before using the linear move command).

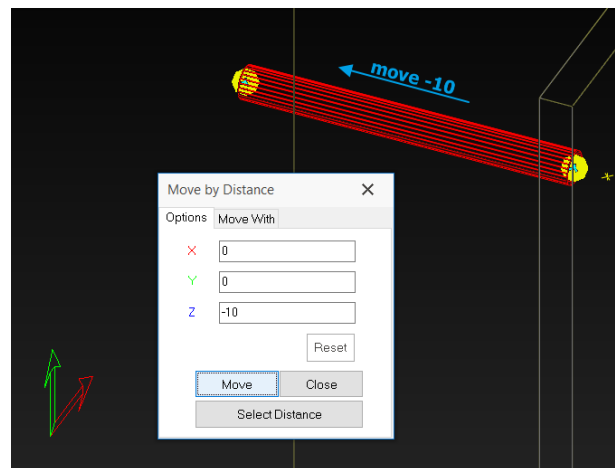

11. Go back to **Section Elevation View**, hold **Shift + left**, click on **joist** to access the **Default Joist Setting**, and set Profile name: **D20**. Then, left-click on the reference point at the left top corner to start creating the rebar → press **Enter** → key in "dz-5" and press **Enter** again.

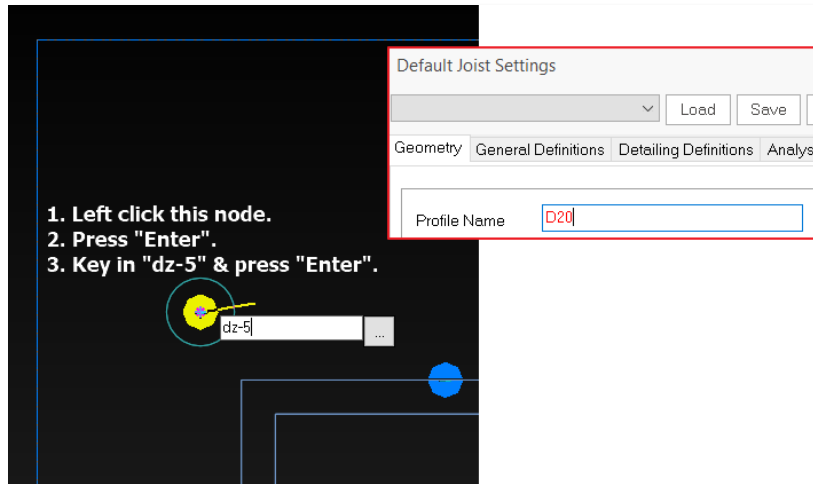

12. Go to 3D view with **wireframe view mode**, select and right-click the created circle to **move** it to the end of the stud.

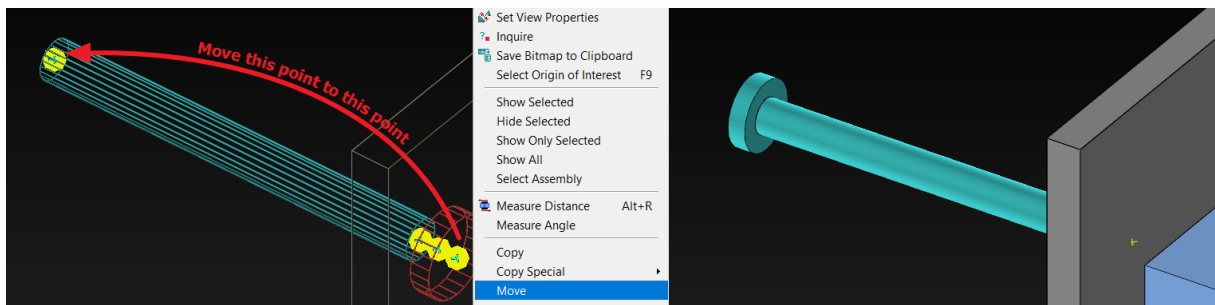

13. Hold **Shift + left click** on **Weld** command (in **Steel** tab) to access the **Default Weld Settings** and set:

- Weld Type: **All-Around**,
- Size: **1**

Click **OK** after setting. Start creating weld by Left-clicking on the command:

- Create Weld between Steel Plate and the stud:
 - i. Click on the weld path that should be welded.
 - ii. Click on the steel plate (which is the larger object)
- Repeat the same steps to create a weld between the stud and the stud end.

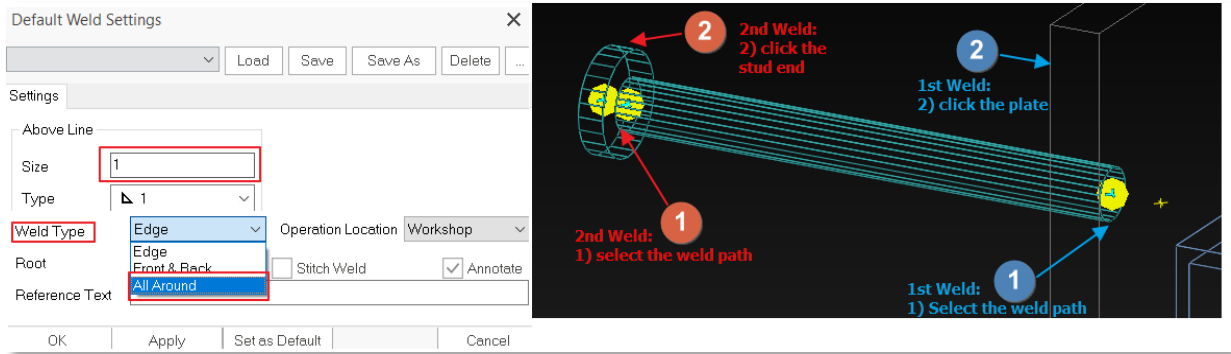

14. Once the welding is finished, copy the stud, including the welding, and paste the rest of the reference points.
15. Repeat the welding steps for the beam to the steel plate.

You may right-click the RC column → **Hide Selected** if necessary.
 Right-click on the background → **Show All** to reveal all the hidden item(s).

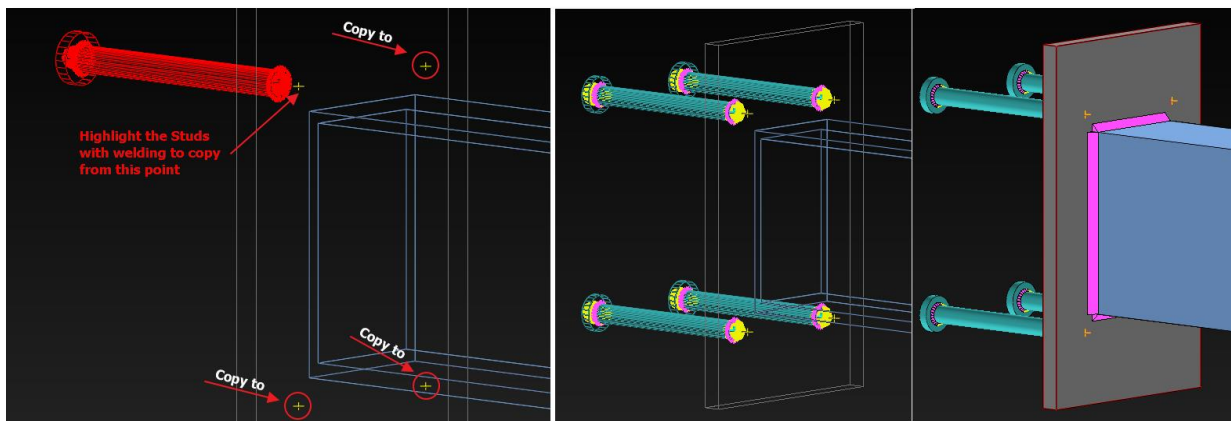

Steel Beam to Steel Column Manual Connection

A steel beam to steel column connection can be done using a manual steel plate connection in ProtaSteel. The steps are somewhat similar to **Steel Beam to Reinforced Column Manual Connection**.

1. Using the Boundary Cut command, we can cut off excessive steel beams (in the **Edit** tab).

(**Object Cut** command is unsuitable because the cutting member can only cut the overlapping volume.)

- I. First, select Member to Cut.
- II. Second, select the Cutting Member.
- III. Select “No” from the pop-out warning to remain the Cutting Member.

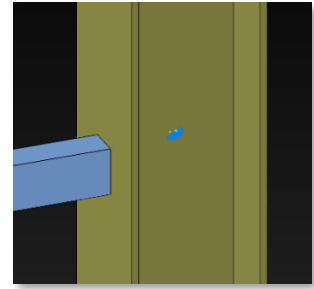

2. Repeat steps 2 to 5 in Steel Beam to Reinforced Column Manual Connection.

3. Hold **Shift + left click** on the plate, set:

- I. Position In Depth: “Front”
(Alternatively, it can be adjusted via hotkey **CTRL+W** in modelling view)
- II. Thickness (t): 10

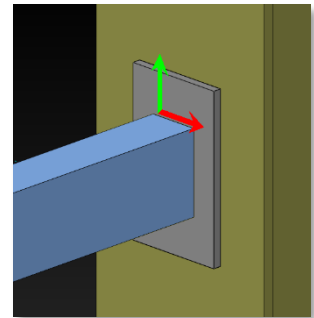

4. Use the **Object Cut** command to cut the beam and the plate—select beam → Select the plate → select “No” in the warning.

5. Now, we can create bolt using **Bolt** command (in **Steel** tab), hold **Shift + left click** to preset the default setting:

- I. In Settings 1 tab → Diameter: **12**
- II. In Positions → Grid:
 - X Positions = **30 60**
 - Y Positions = **-30 -140**

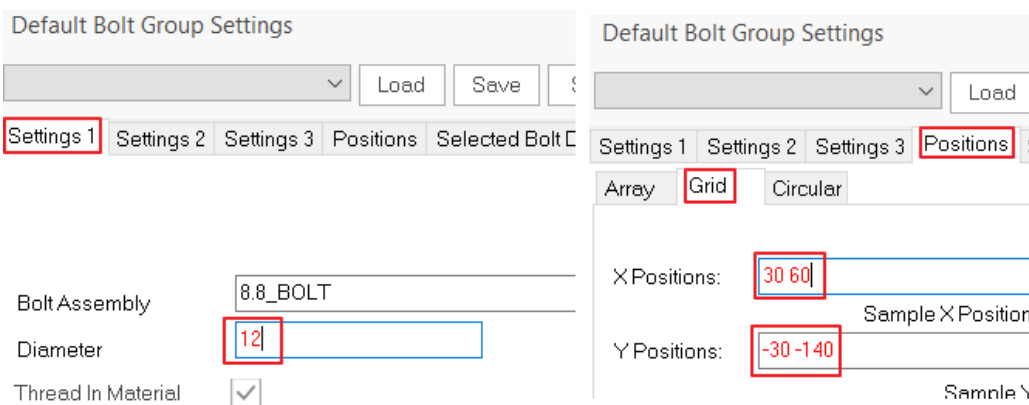

- Click **OK** once finished.

6. Left-click to use the **Bolt** command.
 - I. Select plate and column. Then, right-click once to enter the next stage.
 - II. Select the top left corner of the steel plate and then select the top right corner of the steel plate.

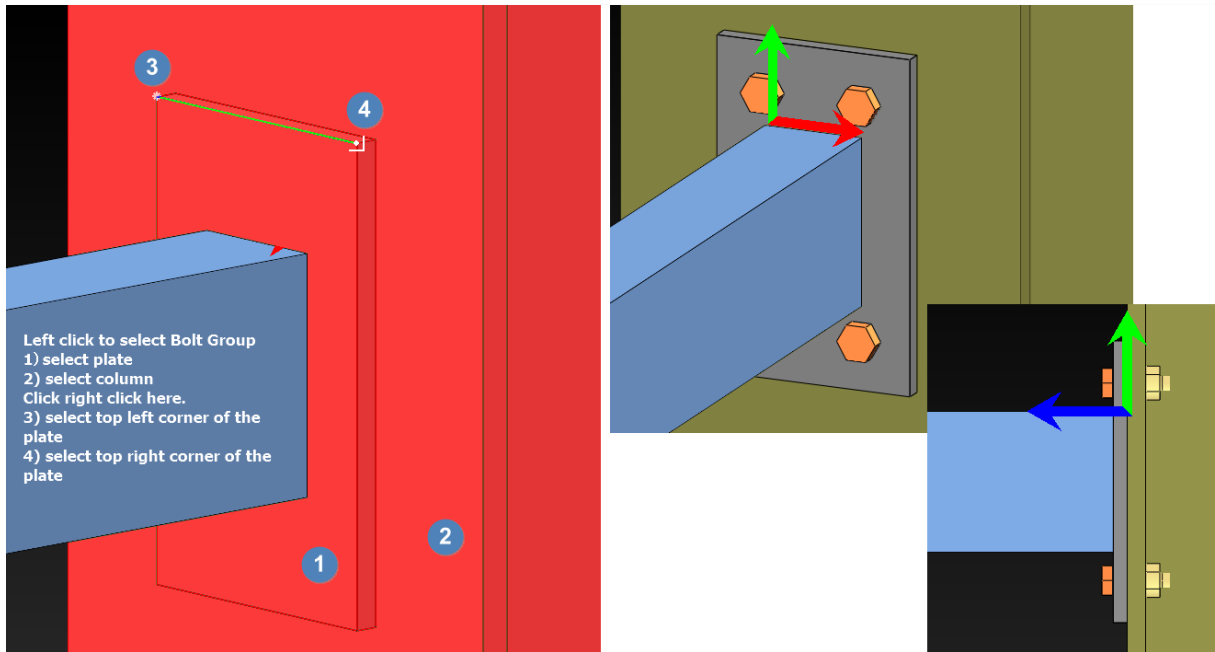

7. Lastly, weld the beam and the plate using the **Weld** command as covered previously.

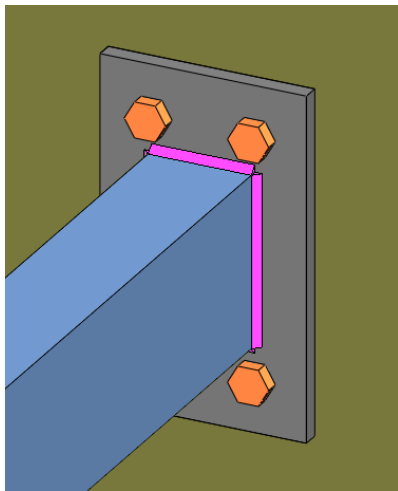

Connection Design Reports

ProtaSteel can create design check reports for the following connections in accordance to **EuroCode3**, **AISC (LRFD)**, **AISC (ASD)**, **BS5950**:

- Beam to Beam Connections: End Plate, Stiffened End Plate, Fin Plate
- Beam to Column Connections: End Plate, Stiffened End Plate, Fin Plate
- Beam to Beam End Plate Connection
- Haunch Connection
- Direct Welding Connection
- Simple Base Plate Connection
- Flange Plate Moment Connection
- Extended End Plate Connection
- Bolted Gusset Plate Connection
- Corner Bolted Gusset Plate Connection
- Welded Gusset Plate Connection
- Corner Welded Gusset Plate Connection
- Apex Haunch Connection
- Splice Connection

ProtaSteel can't create any calculation check for the below connection types.

- Beam to Beam Angle Cleat Connection
- Beam to Column Angle Cleat Connection
- Beam to Beam Fixed Connection
- Wind Column Connection
- Eaves Beam Connection
- Knee Connection
- End Plate Splice Connection
- Fitting Connection
- Sag Rod Connection
- Purlin and Girt Connection
- Welded Pipe Connection
- Welded Box Connection
- Apex Truss Gusset Connection
- Truss End Plate with Gusset Plate

- Batten Plate Connection
- Stiffened Web Opening
- Multiple Stiffened Web Opening
- Beam to Wall Connection
- Embedded Plate Connection
- Manual Connections
- Base Plate Connection
- Hollow Section Base Plate Connection
- Stiffened Base Plate Connection
- Truss Seating Connection
- RC Column Truss Seating Connection

Reports include both geometric checks and capacity checks. In addition, intermediate calculations, references to the appropriate clauses of the design code, and corresponding equations are displayed for easy checking.

Protasteel Fin Plate EC3

1/3
21-Feb-19
2:55:24 PM

Fin Plate 100 Sub 138

UB 250x175x44

UB 300x200x8

UB 250x175x44

UB 300x200x8

64
56
38
0
25
40
4

Connection Info
Connection Name = Fin Plate
Macro ID = 6825
Design Standard = EC3

Supported Beam

Mark = B/D	UB	Grade = S355
h = 244.0 mm	Section = 250X175X44	f _y = 355.00 MPa
b = 175.0 mm	Root rad. = 13.0 mm	f _u = 510.00 MPa
t _f = 11.0 mm	Area = 3549.1 mm ²	t _w = 7.0 mm
	span = 4.71 m	

Bolt Checks
Using elastic bolt analysis for plate

Bolt f _w	800.00 MPa		
Plate f _p	355.00 MPa		
F _x	6.58 kN		
F _y	3.50 kN		
M	-0.58 kNm		
Horizontal force f _i (1,1)	6.70 kN		
Vertical force f _i (1,1)	1.75 kN		
Resultant force f _i (1,1)	6.93 kN		
Horizontal force f _i (2,1)	13.28 kN		
Vertical force f _i (2,1)	1.75 kN		
Resultant force f _i (2,1)	13.39 kN		
Single bolt shear resistance	77.18 kN	≥ V _{Ed} 13.39 kN	5.76 Pass EC3 1-8 T3.4
Bolt f _w	800.00 MPa		
γ _{M2}	1.25		
$F_{v,Rd} = \frac{a_v f_{wB} A_s}{\gamma_{M2}}$			
Bolt bearing resistance	114.31 kN	≥ V _{Ed} 13.39 kN	8.53 Pass EC3 1-8 T3.4
Bolt diameter	16.0 mm		
Thickness	8.0 mm		
Bolt f _w	800.00 MPa		
γ _{M2}	1.25		
f _p	355.00 MPa		
f _t	510.00 MPa		
$F_{b,Rd} = \frac{k_1 a_b f_u d t}{\gamma_{M2}}$			
Bolt group external tearing (top)	84.68 kN	≥ V _{Ed} 1.75 kN	48.37 Pass EC3 1-8 T3.4
Single bolt tearing resistance	84.68 kN		
Bolt group external tearing (right)	84.68 kN	≥ V _{Ed} 13.28 kN	6.38 Pass EC3 1-8 T3.4
Single bolt tearing resistance	84.68 kN		

The reports can be created on-demand in rich text format (RTF). Design Status colors can be seen on model view before report creation. To show the utilization ratio of the connection visually:

- Go to view (tab) → Color Coding → Connection Design Ratio Coloring

The connection will color coded : **Yellow** = Not checked/designed; **Green** = Pass; **Red** = Fail.

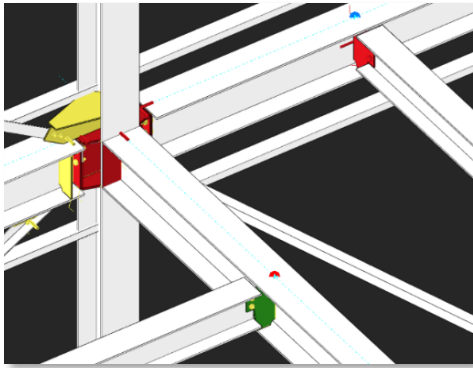

To check the connection & generate the report :

- Select the connection by any of these methods :
- Select the connection **macro sign** 
- Select any component of the connection (eg. a plate or a bot) → then press “M”
- Left click and drag a window enclosing the entire connection
- Hold down **CTRL** to multiple select

- **Right-Click** → Connection Design Reports (or Go to **Drawings & Report** (tab) → **Create**) → Select the desired report :
- **Show Connection Report** → Show connection report of selected macro(s)
- **Default Connection Report** → Create connection report according to project preference
- **EC3 / BS5950 / AISC_LFRD / AISC_ASD Connection Report** → Create connection report for the selected code

Connection Design Summary Table

The connection design summary table presents details about selected connection macros. The summary table shows the “Frame Id”, profile types of macro dependents, connection type, the capacity ratio of connection, design status according to capacity ratio, and whether a design report is created.

- **Select** one or more connection macro
- If no macro is selected, the table will show all supported macros in the model
- Go to Drawings & Reports (tab) → Design Summary

Connection Design Summary Table



Frame IDs	Profiles	Macro IDs	Connection Type	Capacity Ratio	Design Status	Design Report
2C4 - 2X8 [L100X10]	HE200A - L100X10	10909		0.041 < 1	Pass	<input checked="" type="checkbox"/>
1B9 - 1X4 [L80X8]	IPE160 - L80X8	8894		0.011 < 1	Pass	<input checked="" type="checkbox"/>
1C3 - 1B1	HE200A - IPE240	10647	Haunch Connection Macro	1 >= 1	Fail	<input checked="" type="checkbox"/>
1B9 - 1B10S	IPE160 - IPE100	8837	Fin Plate Connection	1 >= 1	Fail	<input checked="" type="checkbox"/>
1B7 - 1X1 [L80X8]	IPE240 - L80X8	9308		0.012 < 1	Pass	<input checked="" type="checkbox"/>
1B6 - 1X1 [L80X8]	IPE240 - L80X8	8544		0.012 < 1	Pass	<input checked="" type="checkbox"/>
1B7 - 1X1 [L80X8]	IPE240 - L80X8	9286		0.012 < 1	Pass	<input checked="" type="checkbox"/>
1B2 - 1X1 [L80X8]	IPE240 - L80X8	8647		0.012 < 1	Pass	<input checked="" type="checkbox"/>
1B9 - 1X3 [L80X8]	IPE160 - L80X8	8975		0.009 < 1	Pass	<input checked="" type="checkbox"/>
1B6 - 1X3 [L80X8]	IPE240 - L80X8	8514		0.009 < 1	Pass	<input checked="" type="checkbox"/>
1B9 - 1X3 [L80X8]	IPE160 - L80X8	8941		0.018 < 1	Pass	<input checked="" type="checkbox"/>
1B2 - 1X3 [L80X8]	IPE240 - L80X8	8617		0.018 < 1	Pass	<input checked="" type="checkbox"/>

The top icons from left to right :

- **Update** → Refreshes the table
- **Show in Model** → Locate & zoom in the selected macro in the model view. Double-clicking on any row will also perform the same function.
- **Create Report** → Create the connection design report of the selected macro. Hold down CTRL key to multiple select.
- **Open Report** → Open the selected design report

If the connection fails, change the macro properties. If the connection parameters are sufficient, the design status color will be green.

Collision / Clash Checks

Before creating general arrangement drawings, a clash check must be performed for all elements. The clash check will highlight the elements that are clashing or overlapping :

- **Select** all or some elements of the model
- Go to Tools (tab) → Clash Check
- Alternatively, right-click on the model screen and pick **Clash Check**

As a result, the clashing elements will be left selected (in red). Generally, a collision occurs when two or more elements overlap each other. It usually occurs when connections are not made yet. For example, before the haunch connection was made, the beam end flange & web plate overlapped into the column (as shown below).

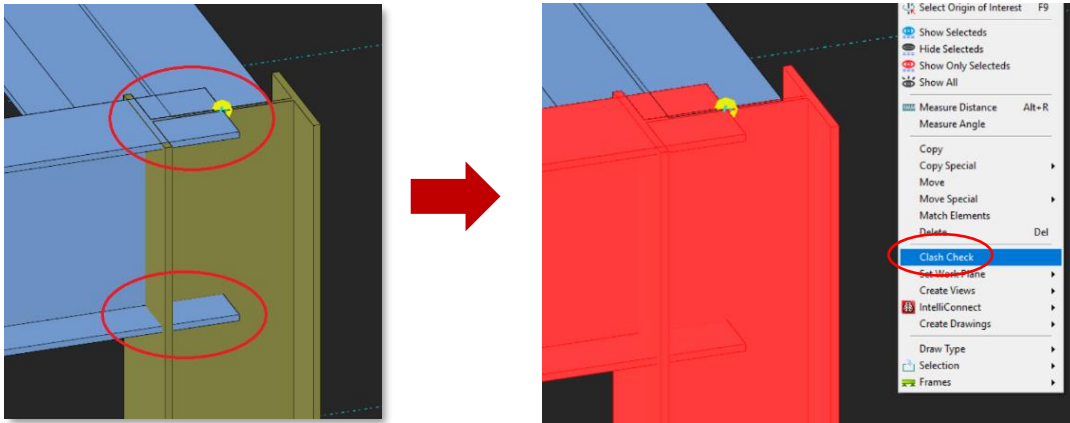

If a Clash Check is performed by selecting both the elements, they will remain selected after the check.

Audit Model

Before creating the detail drawings, it is crucial to determine errors and inconsistencies in the model. This function will perform several model tests, such as duplicate points :

- Go to Tools (tab) → Audit Model
- **Select** the checks desired → **Run Test**

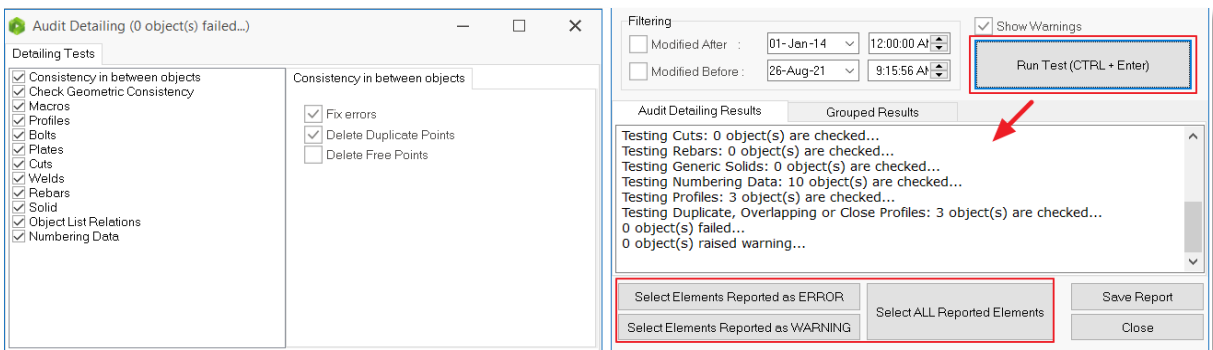

You can select the object(s) specified in the result report and automatically navigate it in the model.

Detailing Item Manager

The **Detailing Item Manager** creates and manages detail items such as the connections. We can use this function to create exploded drawings of the connection with different views and detail information such as dimensions, location of bolts, welds, etc.

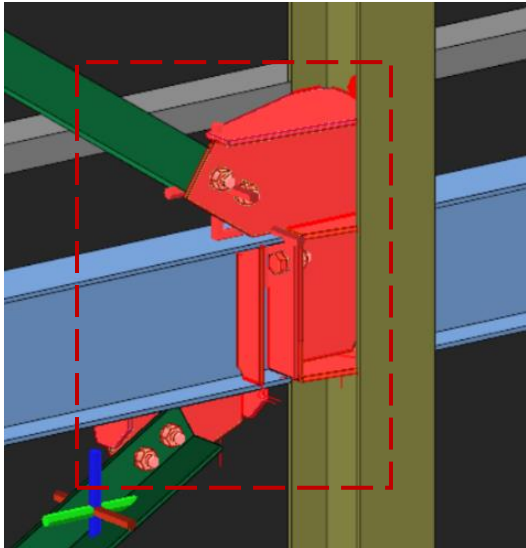
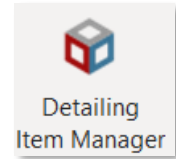

- Zoom into the connection that we have created at **Grid C**
- **Click & drag a window** to select all components of the connections, including all the plate, bolts & welds
- Pick Detailing Item Manager in Steel (tab)

The Detail Item Manager dialog will appear.

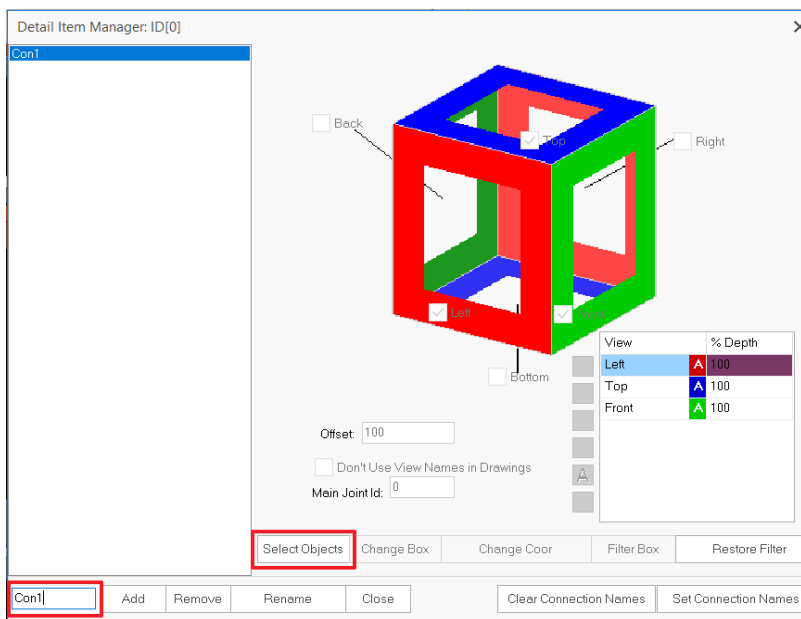

In the Detail Item Manager :

- Type the name "**Con1**" at the bottom
- Pick **Add** → Con 1 will be added
- Pick **Select Objects**
- Select the beam, the column & the 2 braces
- **Right-click**

The moment we do so, a "3D detail box" appears around the connection in the 3D view (as shown below)

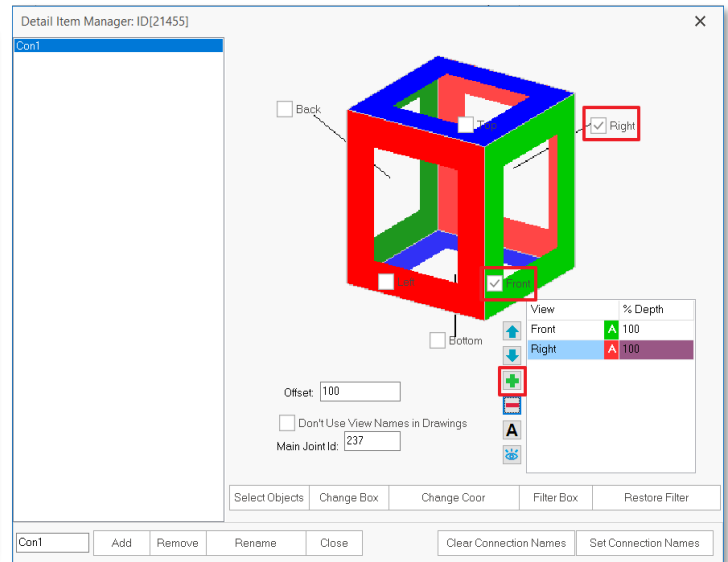
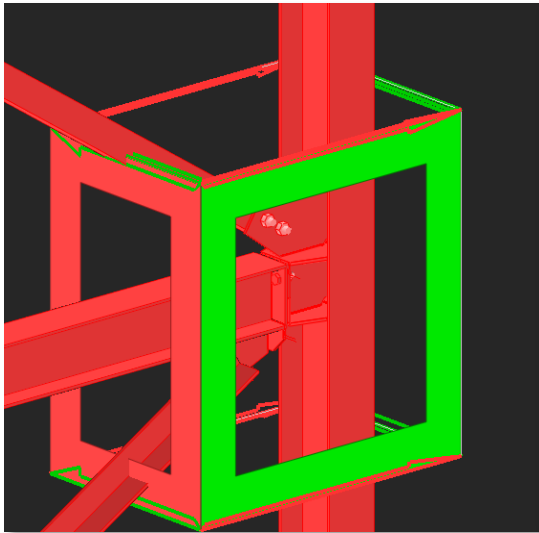

This box controls the various directional views we want to show in the drawings. The view is shown in 3 colors, red, blue, and green. Each color has a front & back view. Hence there is a total of 6 possible views. The view names can be changed – so if the top of the connection is not the actual top, change the name manually.

- For this connection, pick **Front & Right** only, as it's the best viewing direction for this connection.
- Pick **Filter Box** to show only the connection elements (**Restore Filter** will restore all elements)
- Click on the “+” icon to add a 3D view of the connection (if desired)
- **Close** to save & exit the dialog
- Repeat the same steps for the **Splice Connection** at the corner column at **GL D/3**

For practice purposes, we can similarly insert a connection box on the connections we have previously created in Story 1. The summary of steps are :

- Open the view that is most suitable to insert the connection, try **Storey 1 view**
- **Zoom** into connection
- Click & drag a window to select all components of the connections, including all the plates & bolts
- Pick Detail Item Manager in Steel (tab)
- **Add** the connection name
- Click Select Objects & pick all the members of the connection
- **Tick** the desired view direction box
- **Close** the dialog

We have completed the connections and are now ready to generate the drawings.

Preparing Engineering Drawings

ProtaSteel has a powerful tool to prepare engineering drawings – it's simply called the “**Drawing module**”. The drawings are based on the views prepared in the modelling module. The steps are summarized as below :

- Create the desired **Views** in the main modelling view.
- Ensure the orientation of the view you want to use in the drawing is correct, as the drawing module will automatically use the latest views.
 - Double-click on **Axis 3** view → Press **F4** to reset the view to default
 - Double-click on **Storey 1** view → Press **F4** to reset the view to default
- Create any **detail views** such as connection details using **Detailing Item Manager**
- Start the Drawing module by going to **Drawings & Reports** ribbon → click **Drawings** 
- Alternatively double-clicking **Drawings** in the Model Explorer panel (**Ctrl + D**)

Drawing Module

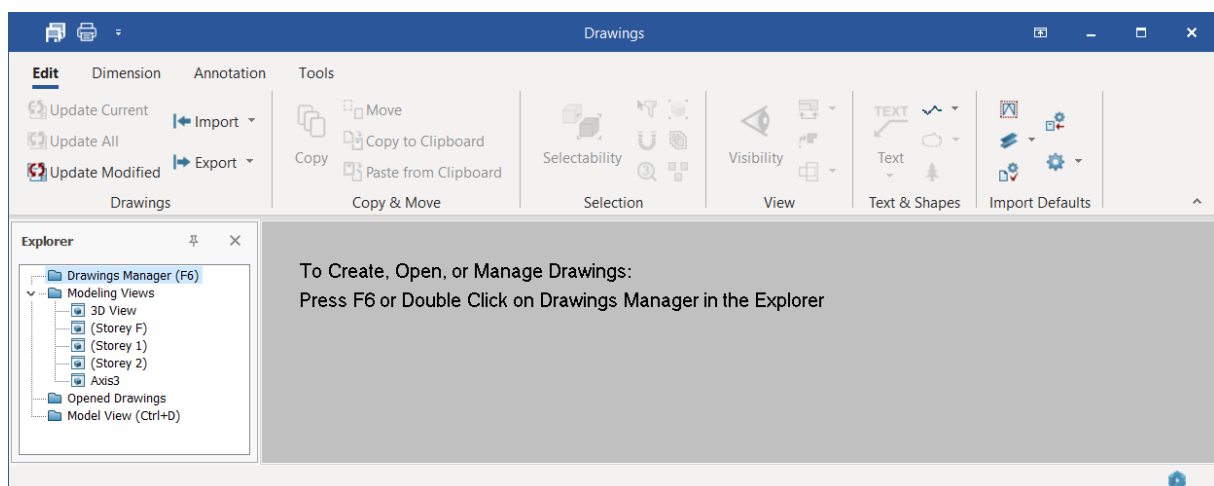

In the Drawings Module, the same views that were shown in the primary model will be duplicated under the Explorer → **Modelling Views** :

- **3D view** – 3D view of the model
- **Storey F** – foundation plan view (ST00 in **ProtaStructure**)
- **Storey 1** – Storey 1 plan view as defined in ProtaStructure
- **Storey 2** – Storey 2 plan view as defined in ProtaStructure
- **Axis 3** – New view along Axis 3
- **Axis A** – New view along Axis A

If you do not have the same views, please close the drawing module to return to the main model & create the view as outlined in previous sections.

Creating Drawings via Drawing Manager

- Double-click on **Drawing Manager** (or F6)

The Drawing Manager is where you can start a new drawing.

The View Manager allows you to manage the drawings:

- Create a new drawing using **Create Drawing** → Create New Drawing Dialog will appear.
- Name the drawing **Storey 1**, Set **Paper Size** to A1 → click **OK**.

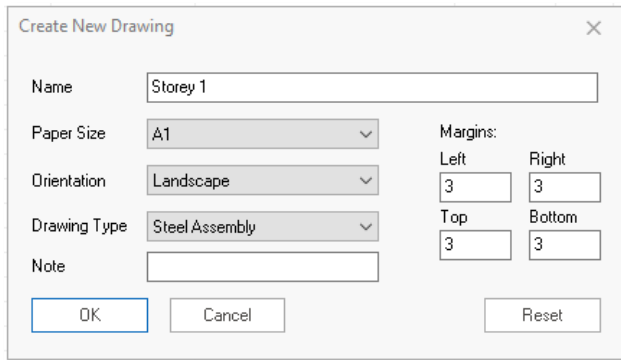

- Storey 1 drawing should be automatically opened.
- If not, select Storey 1 → **Open Drawing**

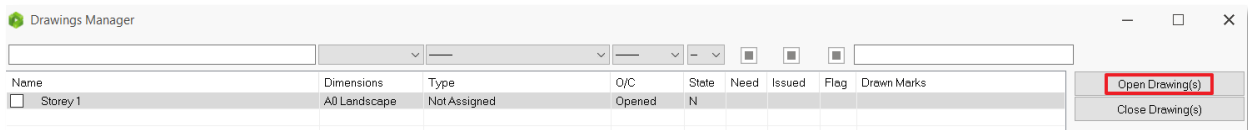

- Close the **Drawing Manager** and the blank drawing will be shown as below.
- Right-click on **Storey 1** located at the explorer panel → **Create Viewport**

The viewport will be inserted into the drawing.

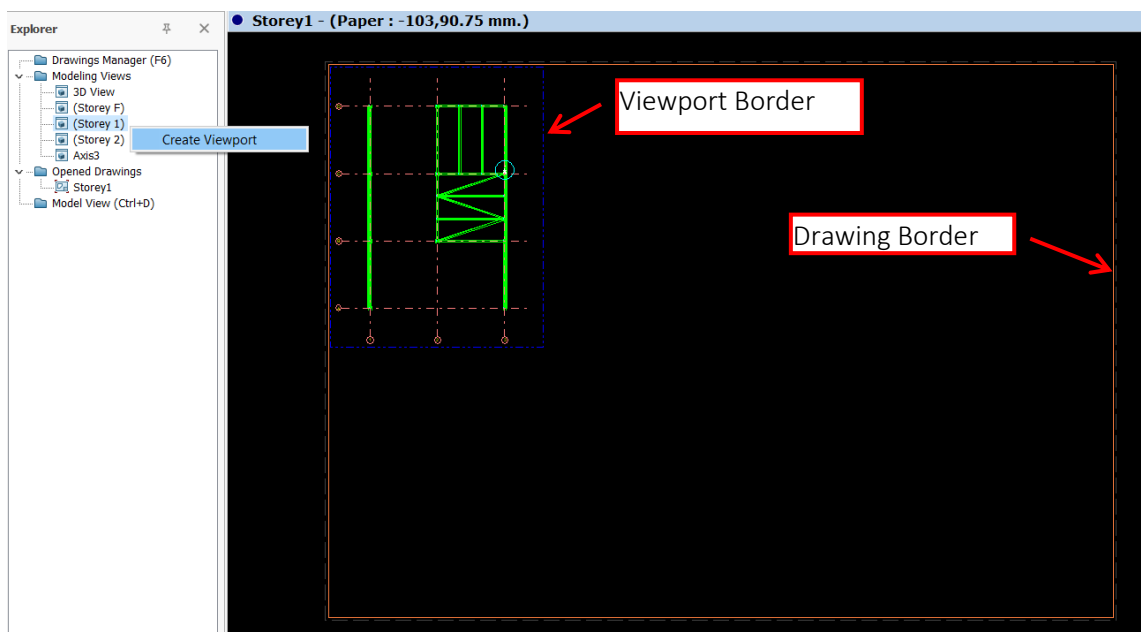

The outermost brown line is the Drawing Border (A1 size). The size & other settings of the drawing can be changed by :

- **Double-click** on any space within the drawing border to access the **Drawing Properties**

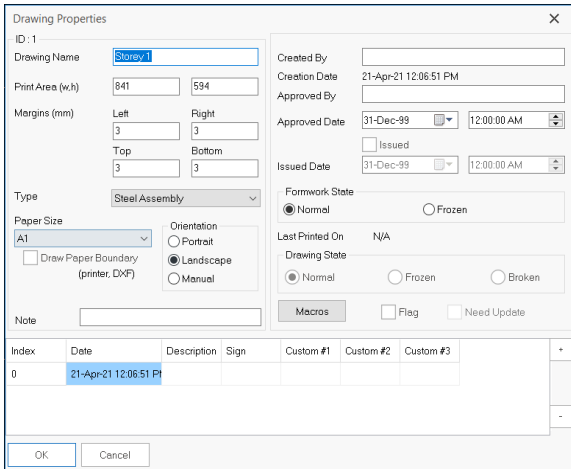

Documents Properties will appear where the following can be changed:

- Drawing Name
- Print Area & Margin
- Paper Size & Orientation
- Created, Approve by, Approved Date
- Document State : Normal / Frozen

The inner **dotted blue line** is the Viewport border which is directly linked to the view :

- Place the mouse cursor at the **lower-right corner** → the cursor will change to resize ↘
- Click & drag to resize & ensure all the elements are visible
- Place the mouse cursor at **the boundary line** → click & drag to move the position of the region
- Double-click any place within the **viewport** to access the **Viewport Properties**
- The region has been renamed **viewport** in the current release

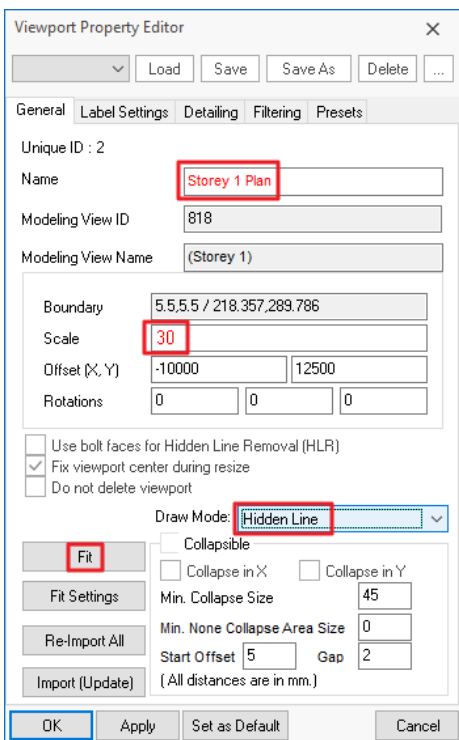

Viewport Property Editor dialog will appear. In the General tab, the following can be changed :

- Name of the region
- Scale
- Offset (X Y): Coordinates of view
- Rotation: States the rotation angle
- Drawing Mode: Line/All Visible/Hidden Line/Full Dashed
- Change the **Name** to **Storey 1 Plan**
- Change say **Scale** to **30**
- Change **Draw Mode** to **Hidden Line** → **Apply**

The drawing will be updated to scale & hidden line.

- Pick **Fit** to autofit all the elements & the new title

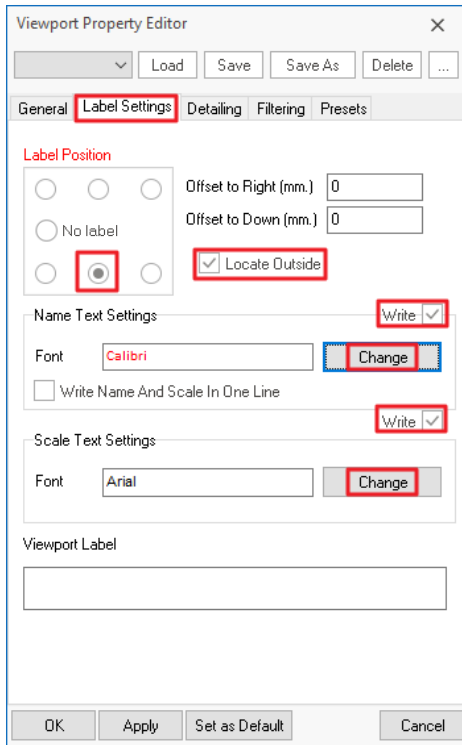

- Go to **Label Settings** tab

The Label Settings dialog allow you to change :

- Label Position
- Offsets
- Name & Scale Text Settings
- Pick **Locate Outside** so the label will be place outside the region border
- Tick **Write** next to Name & Scale Text Settings
- Pick **Change** under Name Text Settings
- Change Name Text Height to **10mm** → OK
- Change Scale Text Height to **10mm** → OK → Apply

Notice that the name and scale appear larger in the drawing.

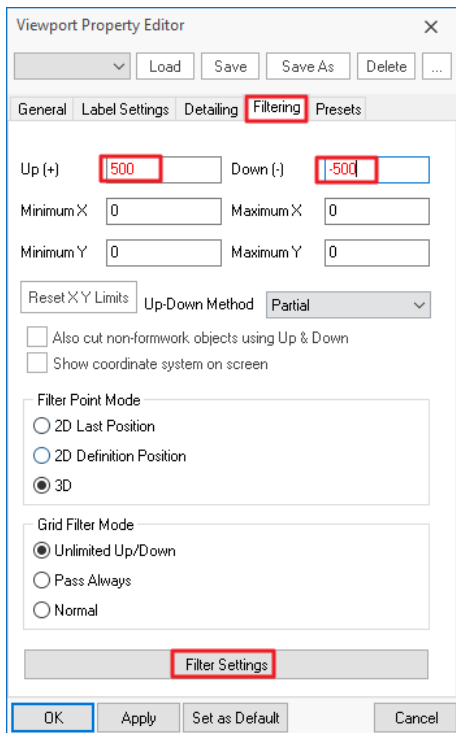

- Go to **Filtering** tab
- The options here controls what is shown in the drawing :
 - Up (+) & Down (-) filters objects in & out of the paper
 - Min X & Max X filters objects in the X plan direction
 - Min Y & Max Y filters objects in the Y plan direction
- **Up-Down Method** :
 - **Partial** : Any element that exists partially within the above extents will be shown
 - **Full** : Only elements that exist fully within the above extents will be shown
- **Filtering Settings** – expose more filter options
- Change **Up(+)** to **+500** & **Down (-)** to **-500** → **Apply** → Girts disappears as they are placed slightly above the floor level
- Pick **Filter Settings**

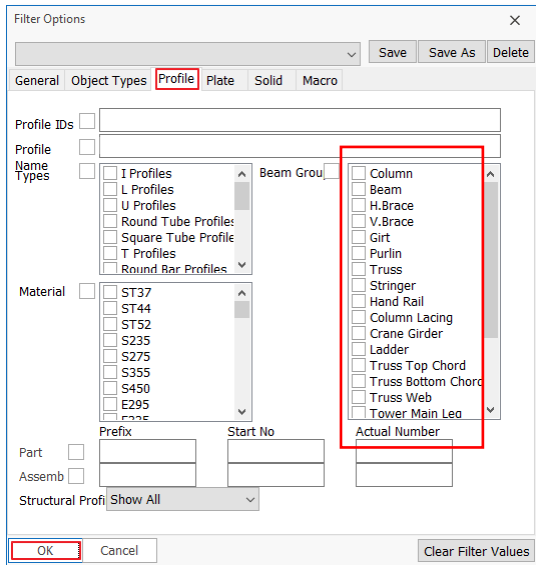

Filter Options enable advance filtering :

- General : Steel, Concrete, Unique ID, etc
 - Object types : Grid, Profile, Joint, Weld, etc
 - Profile : Columns, Beams, Brace, etc
 - Plate : Plate IDs, Types & Usage
 - Solid & Macro
- Go to **Profile** tab
 - Tick **Column, Beam, H. Brace**
 - Pick **OK** to exit

This ensures that only column, beam, and horizontal elements are shown.

Visibility and Selectability in Drawing Module

Visibility settings allow the user to show and hide elements that wish to hide/show in the drawings. In contrast, **Selectability settings** allow the user to lock the elements and prevent them from miss-click or accidentally deleting them.

You may easily access it in the **Edit** tab go to **View** → **Click on Visibility**

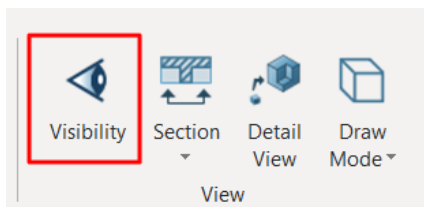

By default, all elements will be ticked. If the selected element is unticked and press **“OK”**, the effect will immediately apply to the selected element in the drawing.

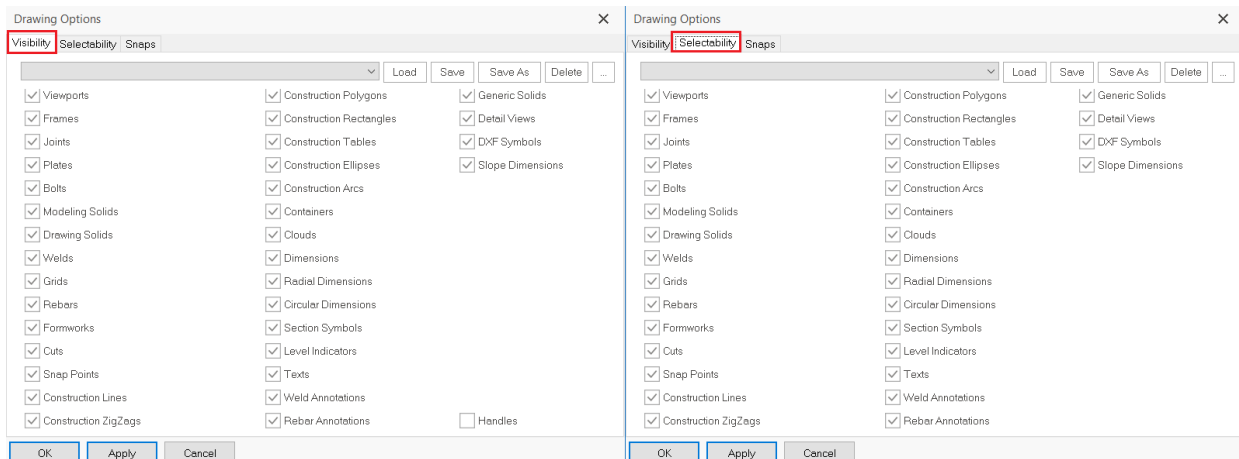

Grid Level Visibility

Now, we will insert the 3D view into the drawing.

- Right-click on **3D View** → Create Viewport

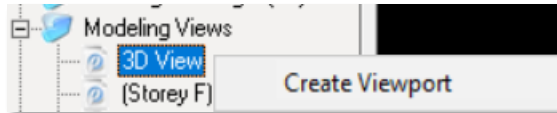

In the 3D view, the grids appear in each storey.

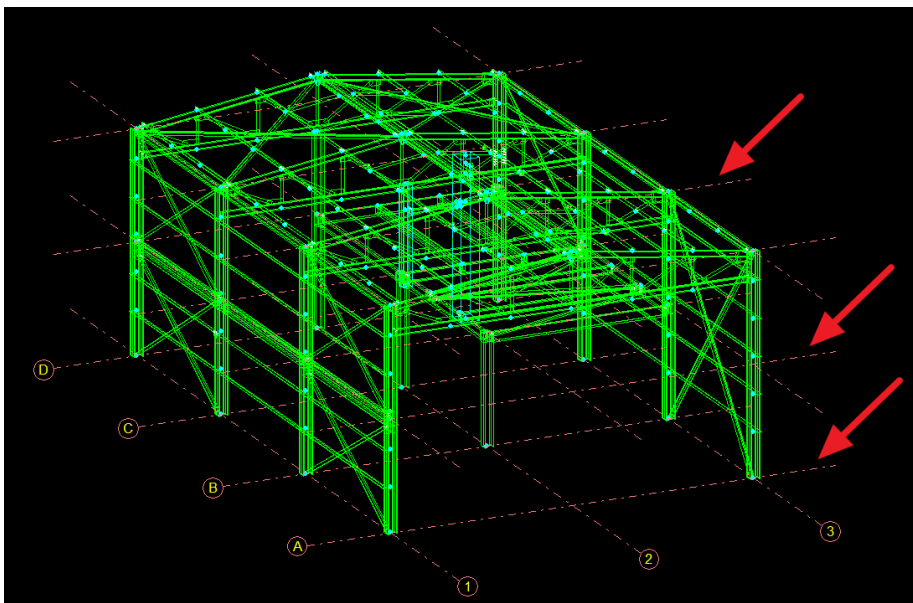

To show the grids at the storey 0 only,

- Double click on any Grid → **Grid Properties Editor** will appear.
- Untick **1. Level** and **2. Level** under Grid Level Visibility → Click **OK**.

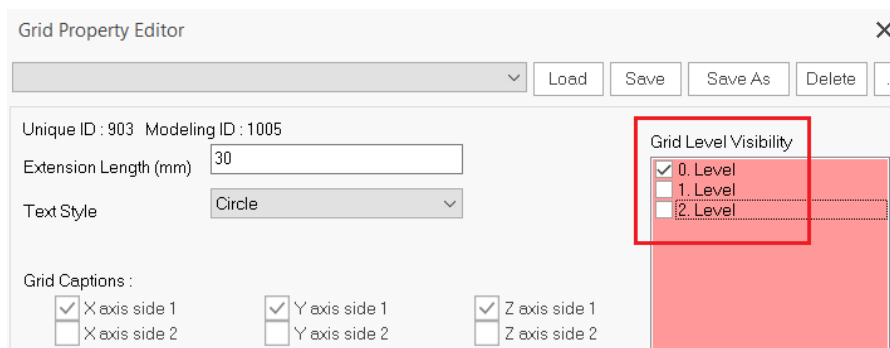

- The 3D view will now look clean.

Profile Annotation

We now add steel profile annotation, i.e., show the member sizes. Firstly, we should select the members we want to annotate. To select the members easily, we can control what elements are selectable:

- Go to **Edit** (top menu) Click on the **Selectability** icon  to access the **Drawing Options** dialog.

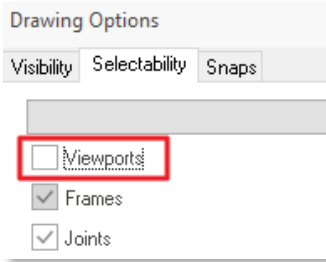

- Untick **Viewport** → OK
- This prevents you from selecting the viewport border.
- The same options are available in **Visibility** tab which controls what is shown in the drawing.

- In the drawing, **left-click & drag a box** around all the steel members to select them
- Click at the bottom arrow of **Profile Annotation** icon → Click **Annotation Settings**

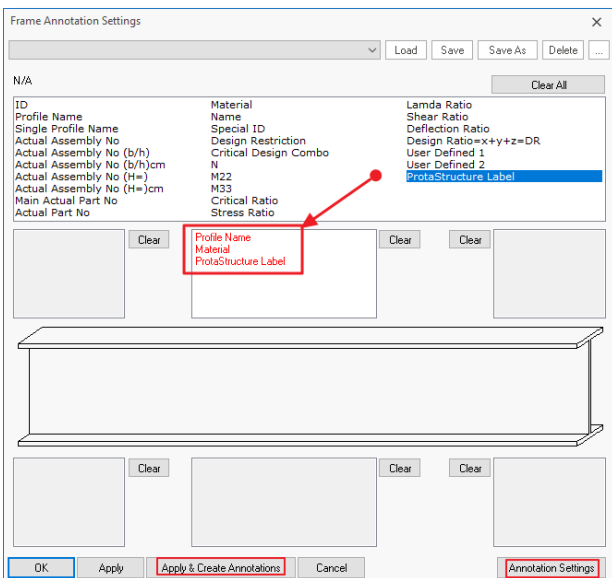
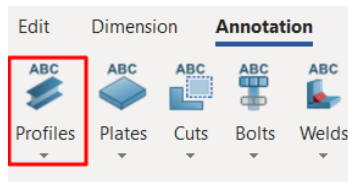

- The settings here control how steel members are annotated (labelled) :
- The various type of annotations is listed in the table
- Click & drag any annotation name into the box which also defines the position of the annotation
 - Click and drag **Profile Name, Material & ProtaStructure Label** in the box
 - Click **Annotation Settings** to view or change the text settings :
 - Font type & size
 - Format or style of the annotations
 - Change the **Text Height** to **7 mm**
 - Click **Apply & Create Annotations**

The annotations are added next to steel members, as shown below.

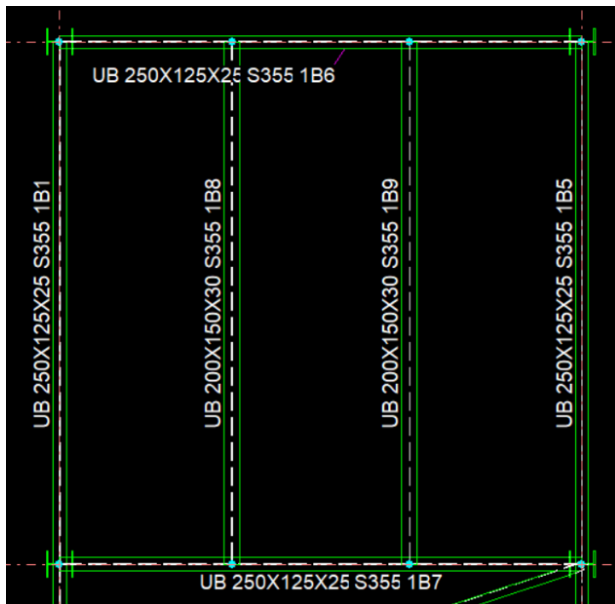

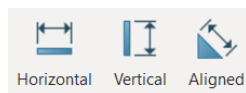

- **ProtaStructure Label** is ProtaStructure member labels such as 1B1, 1C1
- The annotation position can be moved by **left click & drag**
- Annotations can be deleted using the **Delete** key
- Annotation text size, font height, etc. can be changed by selecting them → **ENTER** → **Annotation Text Property Editor**

Dimension

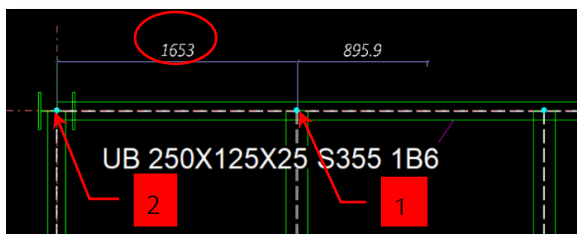

Dimension tools can be used to insert dimensions in the drawing.



- Zoom in the top around primary beam along axis D
- Click Horizontal Dimension 
- **Left-click** on the **1st** point & then the **2nd** point between the points to be dimensioned.
- Move the mouse cursor away to the right

Notice the dimension is shown dynamically.

- Left-click on the **3rd** point & then the **4th** point

- **Move** the mouse cursor to the **exact position** where you want the text to be placed
- **Right-click** to confirm & create the dimensions

The dimensions will be created as shown below.

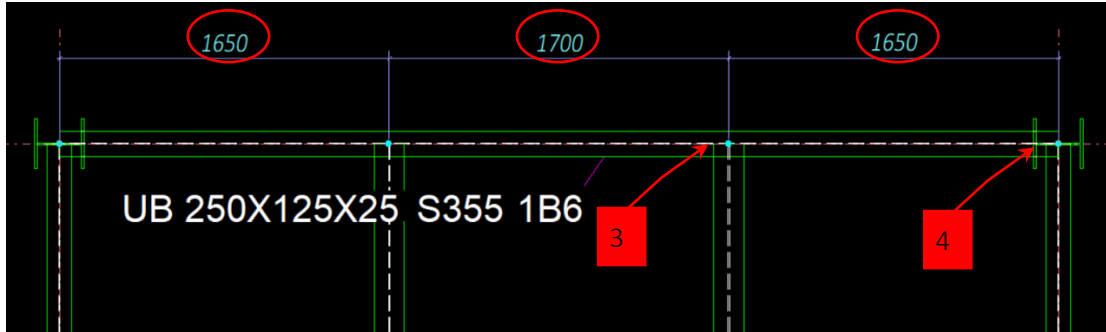

Creating Connection Detail

Let us now create a new connection drawing for the connection we created along **Grid 3**.

- Double-click on **Drawings Manager** (or F6)
- Pick **Create Drawing** → Create Drawing Dialog will appear

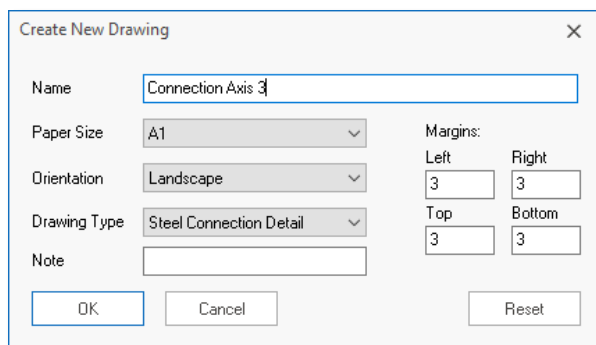

- Name it **"Connection Axis 3"**
- Change the **Paper Size** to **A1** → Orientation = **Landscape**
- Pick Drawing Type = **Steel Connection Detail**
- Pick **OK** → The drawing will be created & automatically opened
- **Close** the Drawing Manager dialog (Pick **YES** if prompted to save)

The drawing **"Connection Axis 3"** will be opened and brought to focus. The drawing is empty & we will insert the required view into the drawing.

- Right-click on Axis 3 View → **Create Viewport**

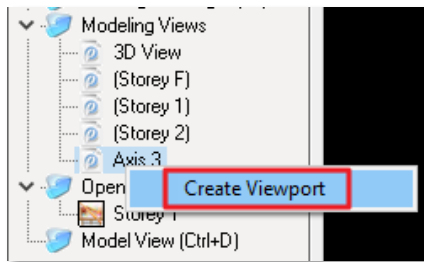

The viewport will be inserted into the drawing.

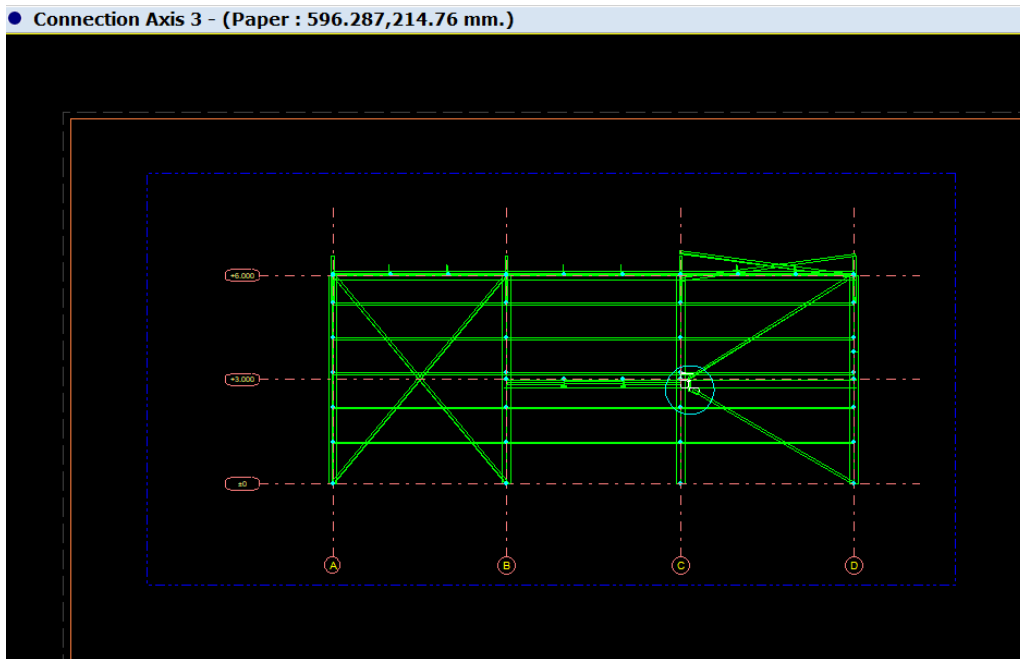

As explained previously, if it is not positioned correctly, you can click and drag the blue view port border to reposition it. If you cannot select the blue border :

- Click on the **Selectability** icon  at the top menu to access the **Drawing Options** dialog

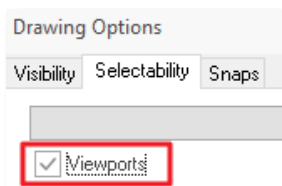

- Tick **Viewport** → OK
- **Click & drag** the viewport into the Drawing Sheet

- **Double-click** anywhere in the Connection Detail Drawing viewport to call out Viewport Property Editor.
- In this dialog, you can set the details of the connection drawing, such as the scale and Annotation

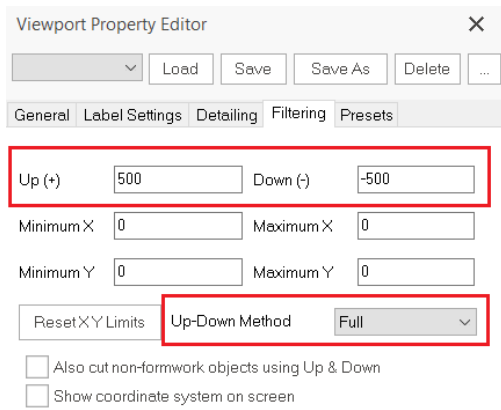

Viewpoint Property Editor

General Label Settings Detailing Filtering Presets

Up (+) 500 Down (-) -500

Minimum X 0 Maximum X 0

Minimum Y 0 Maximum Y 0

Reset X Y Limits Up-Down Method Full

Also cut non-formwork objects using Up & Down

Show coordinate system on screen

- Double-click on the region to access the Viewport Property Editor
- Scale can be change but let's leave it as default
- Go Filtering tab → change Up = 500 & Down = -500
- Up-Down Method → change to **Full**
- **OK** to close the dialog

The drawing will show only members that are fully within the Up & Down extents.

Notice there is a circle around the connection – this is directly linked to the connection box created in the main model, which will be used to create the detail connection drawings.

To create this connection drawing :

- Go to **Tools** (top menu) → locate **Connection Detail Drawings** icon 
- **Shift + Left click** this icon to call out the settings of Connection Detail Drawing Macro.

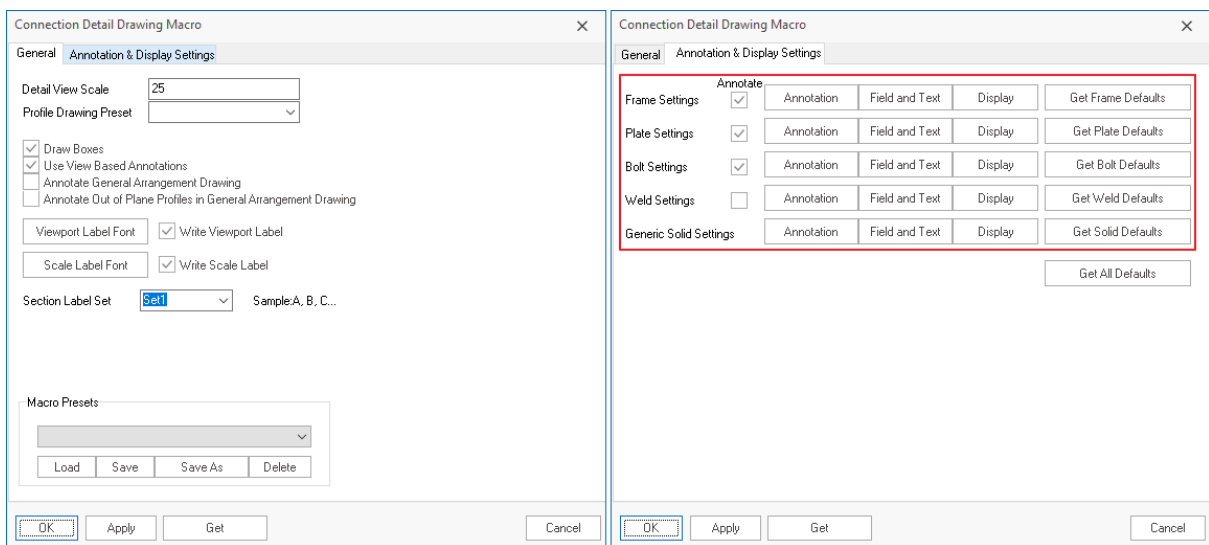

Connection Detail Drawing Macro

General Annotation & Display Settings

Detail View Scale 25

Profile Drawing Preset

Draw Boxes

Use View Based Annotations

Annotate General Arrangement Drawing

Annotate Out of Plane Profiles in General Arrangement Drawing

Viewport Label Font Write Viewport Label

Scale Label Font Write Scale Label

Section Label Set Set1 Sample: A, B, C...

Macro Presets

Load Save Save As Delete

OK Apply Get Cancel

Connection Detail Drawing Macro

General Annotation & Display Settings

Annotate

Frame Settings Annotation Field and Text Display Get Frame Defaults

Plate Settings Annotation Field and Text Display Get Plate Defaults

Bolt Settings Annotation Field and Text Display Get Bolt Defaults

Weld Settings Annotation Field and Text Display Get Weld Defaults

Generic Solid Settings Annotation Field and Text Display Get Solid Defaults

Get All Defaults

OK Apply Get Cancel

- Under **Annotation & Display Settings**, review Annotation, Field, and Text & Display
- If there are any changes, click **OK** to save & exit.

- Click on **Connection Detail Drawing Macro** icon 

The Connection Detail will be inserted into the drawing as shown below.

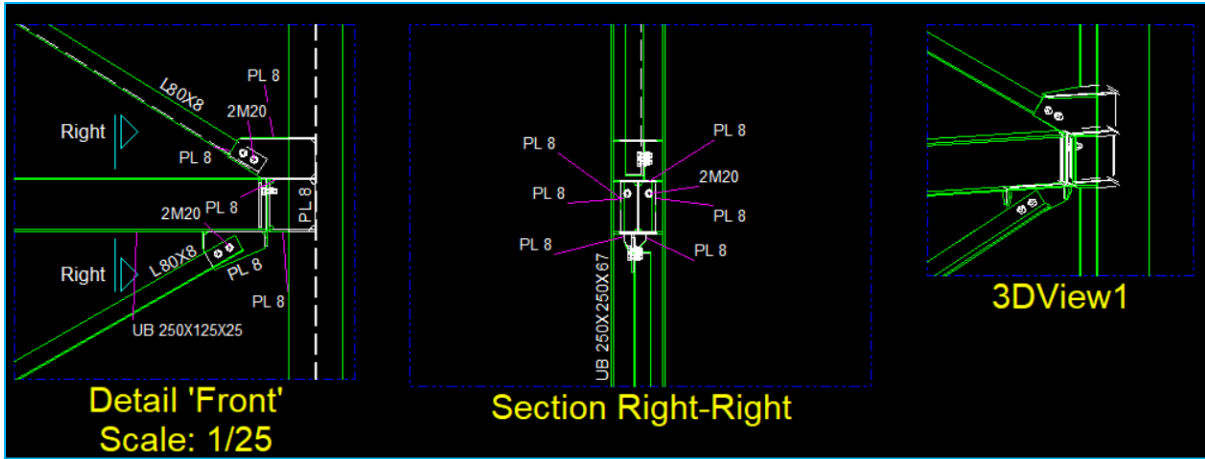

Further customization of the connection detail can be done.

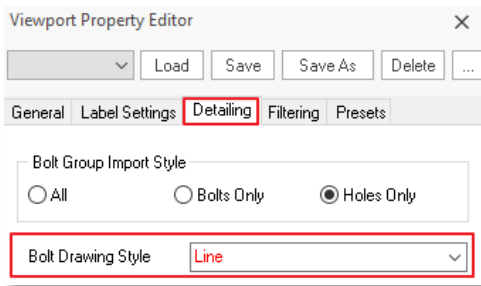

- Double-click in the detail region of the connection to access the **Viewport Property Editor**
- Under **Detailing** tab, you can change :
 - Bolt Import Style
 - Bolt Drawing Style
- Try the various options & click **Apply**

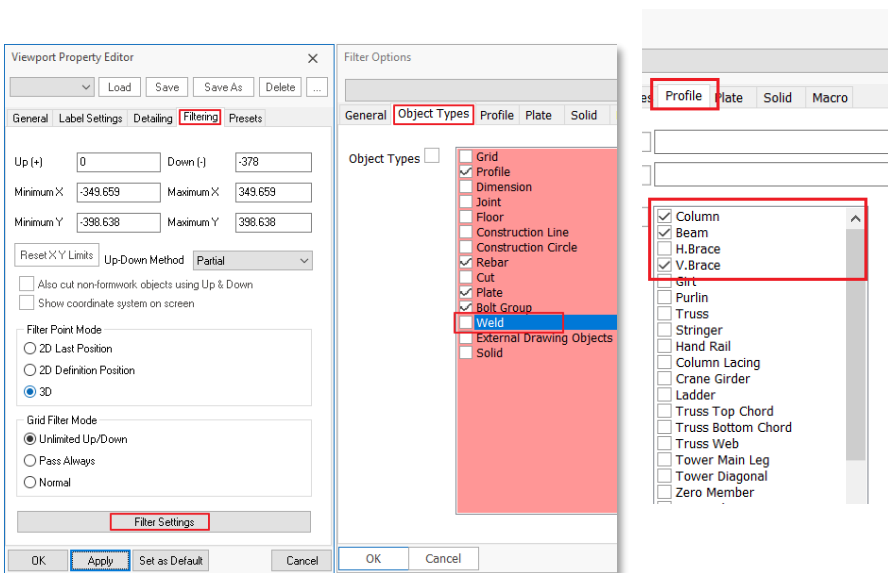

- Go to **Filtering** tab → Pick **Filter Settings**
- Go to **Profile** → check **Columns, Beams & V. Brace**
- Go to **Object Types** → Untick **Weld**
- Click **Apply** → **OK**

This will only show relevant members of the connection. The welds shown in thicker lines will be hidden, assuming you may want to show welding in another drawing.

Plate, Bolts & Weld Annotation Tools



The bolts, plates, and welds are automatically annotated in the above example. If you wish, you can manually do so by using the plate, bolts & weld annotation tools under **Annotation** ribbon

- Hold down **CTRL** key → select all the annotations of the “Front” detail → delete them
- **Click & drag a window** (right to left) to select bolts & plates to be annotated (does not matter if other objects are selected)

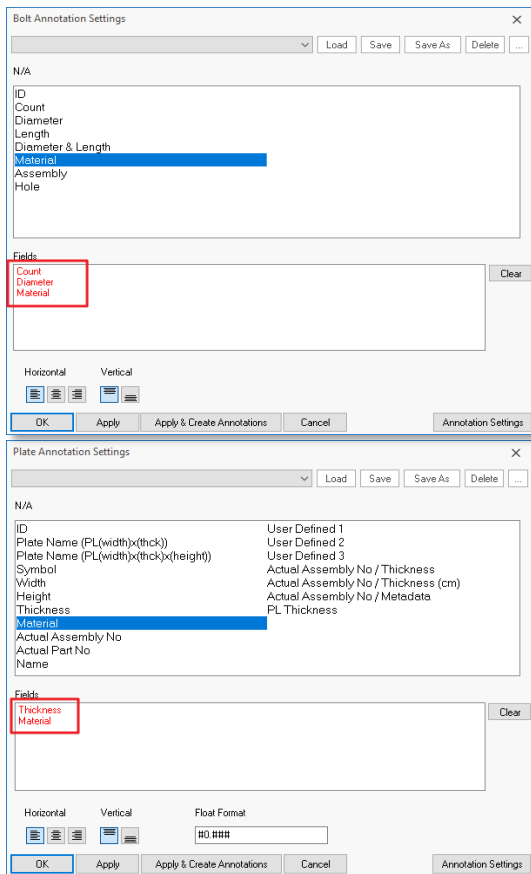

- Click on the arrow below of **Bolt Annotation** Bolts to access the **Annotation Settings**
- Pick **Clear** to remove existing settings
- Click & Drag **Count**, **Diameter** & **Material** to the bottom Fields
- Pick **Annotation Settings** to view/change font type, color, etc → **OK**
- Pick “**Apply & Create Annotations**”

- Click on the arrow below of **Plate Annotation** Plates to access the **Annotation Settings**
- Pick **Clear** to remove existing settings
- Click & Drag **PL Thickness**, & **Material** to the bottom Fields
- Pick **Annotation Settings** to view/change font type, color, etc → **OK**
- Pick “**Apply & Create Annotations**”

You should get details similar to the figure shown below (depending on your preference).

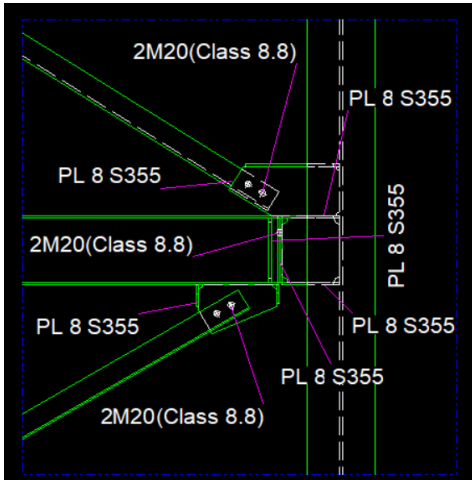

- The drawing can be further improved by :
- Go to Viewport Properties Editor and change the Scale
 - Change **Offset (X,Y)** to reposition the connection
 - **Delete** any annotations that you think is not required
 - **Click & drag** the annotation to reposition it

Numbering Objects

Before parts and assembly views & drawings can be created, the objects must be numbered. By default, all objects are included in the same numbering group. To assign objects to different groups:

- Double-click on a steel member in the ProtaSteel to open the **Profile** dialog.
- In the Detailing Definitions tab, input Drawing Group number

This feature was developed to number the different parts of the structure separately.

The Prefix & Start Number can be specified for each group of objects.

After the numbering process, the actual part and assembly number will be shown under “**Actual Number**”.

- In Model View, Go to Drawings & Reports (tab) → **Perform Numbering**

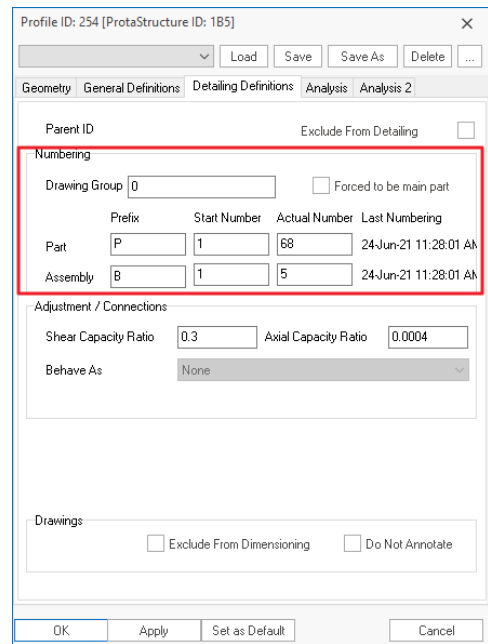

The Numbering Options dialog will appear.

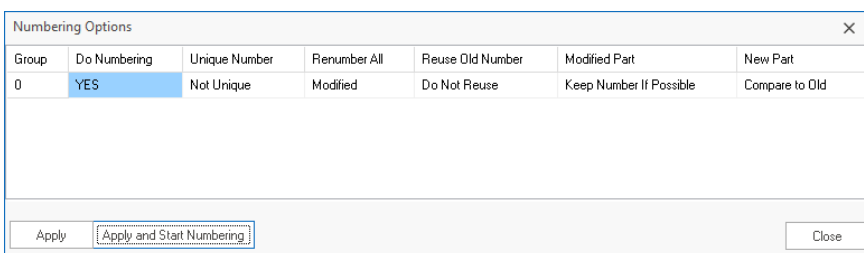

As the model is continuously revised, the numbering process needs to be repeated. **ProtaSteel** has extensive options for renumbering. Numbering Options can also be configured according to the

preferences of the manufacturer. For example, there is an option to force the geometrically identical part to have the same number.

Do Numbering

- Specifies whether to number the selected group

Unique Number

- **Unique:** Can be selected for reinforced concrete elements. Objects are given a different number regardless of their geometric properties (beyond the scope of **ProtaSteel**)
- **Not Unique:** Should be used for steel model. Makes numbering by looking at geometry and material properties.
- **Spatial Sort:** Can be selected for the reinforced concrete model. This option performs numbering according to the object's position. The object's reference point is sorted first by X and then by Y. Different groups should be made for different levels. Consecutive numbered column and beam applications can be an example.

Renumber All

- **Modified:** Number only the modified objects. Ignores objects that have not changed.
- **Renumber** number all objects.

Reuse Old Numbers

- **Reuse:** Uses old numbers.
- **Do Not Reuse:** Don't use old numbers. After the changes, there may be no elements belonging to a number. Specifies whether to use this number for a new element.

Modified Part

Suppose that we have three quantities of P5 and two quantities of P7. The three quantities of P5 have the same change and become the same as the P7.

- **Keep Number If Possible:** Retains the numbers if possible after the change. If this setting is used, the result is still three quantities P5, two P7.
- **Compare to Old:** Compares and assigns the part-marks from the previous numbering if possible. If this option is used, the result is five quantities of P7.
- **Take New Number:** Assigns new part-marks. This option will lead to two P7 and three P8.

New Part

Similar to "Modified Settings". It only applies to newly created objects. Hence, there is no option to "Keep the Number If Possible".

- **Compare to Old:** Compares and assigns the part-marks from the previous numbering if possible.
- **Take New Number:** Assigns new part-marks.

Creation of Parts and Assembly Drawings

If there are no problems after the Audit Model, Clash check, and numbering, the parts and assembly drawing can be produced.

You can create the part & assembly drawing for the entire model or some objects.

- **Select** the entire model or objects
- Go to Drawings & Reports (tab) → Create Drawings → Create Assembly Drawing / Create Part Drawing

The Drawing Module will be launched, and the drawings created.

- In the **Drawing Manager** → Double-click to open & review the drawing

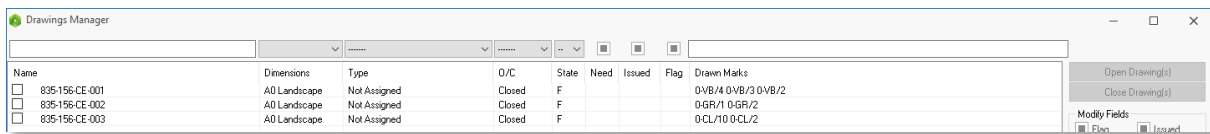

Name	Dimensions	Type	O/C	State	Need	Issued	Flag	Drawn Marks
<input type="checkbox"/> 835-156-CE-001	A0 Landscape	Not Assigned	Closed	F				0VB/4 0VB/3 0VB/2
<input type="checkbox"/> 835-156-CE-002	A0 Landscape	Not Assigned	Closed	F				0GR/1 0GR/2
<input type="checkbox"/> 835-156-CE-003	A0 Landscape	Not Assigned	Closed	F				0CL/10 0CL/2

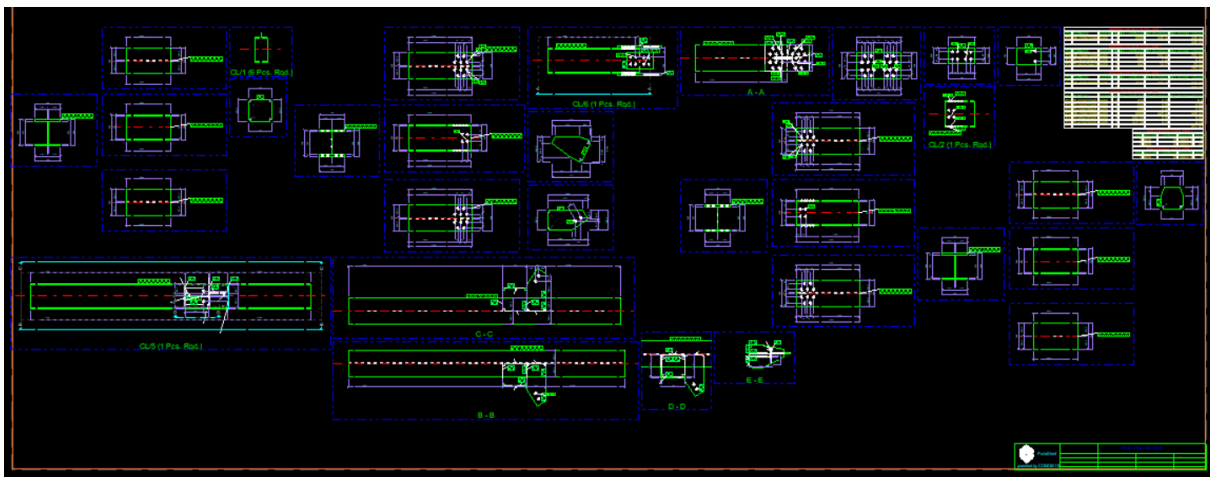

Import Titleblock using DXF Import

In **ProtaSteel**, users can import title blocks and print drawings directly.

- Users can import company standard title block as DXF in Drawing Module by going to **Edit** → **Import** → **Import DXF**

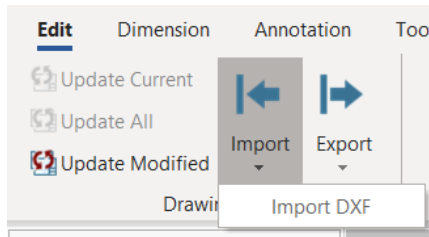

- Select the company standard title block DXF directory.
- Paper Anchor and DXF Anchor set to **Bottom Right**.

Ensure the imported drawing contains only the title block. Block references can not be recognized. In addition to this, drawing units must be set correctly.

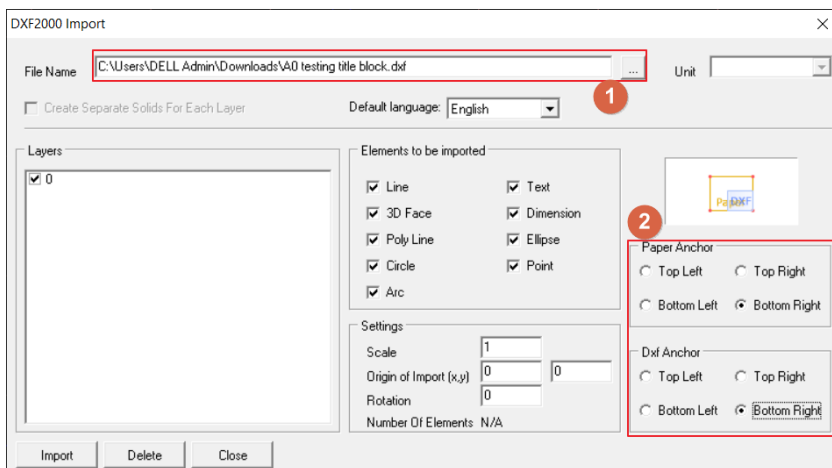

- Titleblock annotation can be inserted/modified using the **“Text”** Function.

Text & Shapes

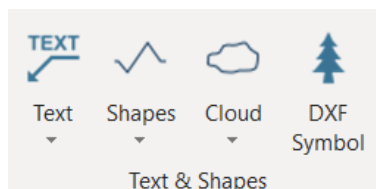

Text & Shapes allow users to add details to the drawings such as the opening dash line, “to be continued” line, revision cloud, description, etc.

- If you wish to select a point with no object snap, you can hold **left ALT** to select a free point.

- Please hold the left CTRL before selecting the start point to draw it horizontally.
- If you wish to draw it vertically, please hold the **left SHIFT** before selecting the start point.

DXF Export

All the drawings created in ProtaSteel can be exported as DXF format :

- Double-click on **Drawing Manager (or F6) → DXF Export**
- Under **DXF Export → Pick Settings**

In the **DXF Export Settings**, you can choose the layers to be exported, change the Layer Name & Line Type.

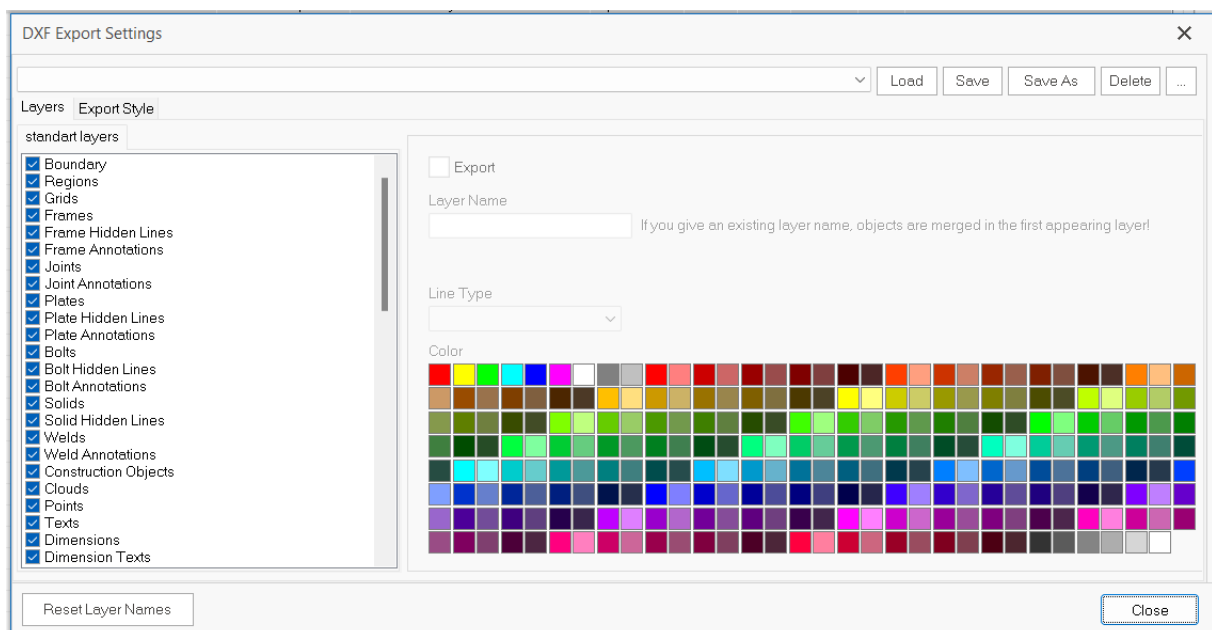

- **Close** the DXF Export Settings
- Pick **Export** → Choose the destination folder → **OK**

The DXF drawing will be created in the folder selected.

IFC File Export

ProtaSteel model can be exported as Industry Foundation Classes (IFC) file. IFC is a Building Information Modeling (BIM) data structure created by BuildingSmart International and is the ISO 16739: 2013 standard. Most design software implements the IFC File format, including leading Building Information Model (BIM) platforms like Autodesk Revit, Bentley, and Tekla Structures. Wide-spread usage of the IFC format facilitates sharing of building information models between various BIM platforms.

- **Select objects** to be exported as IFC file format.
- If no object is selected, then all objects will be exported.
- In Model View → **BIM** (tab) → **Export IFC File**

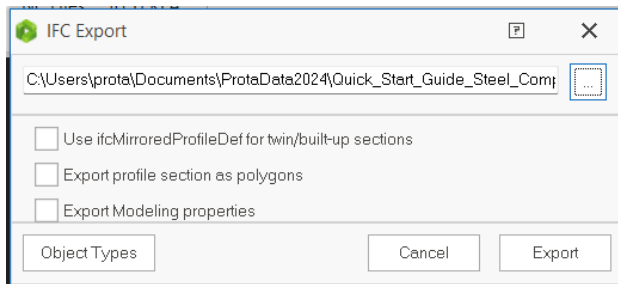

- Click '...' to specify the file name and location to export
- Check the desired export options → **Export**

Material Takeoff

ProtaSteel automatically creates material lists of the whole of the steel structure. **Material Lists** is located under the **Drawing and Reports** tab.

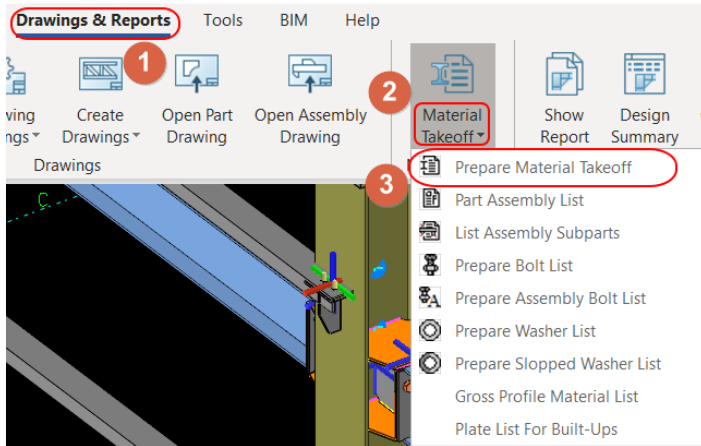

There are two methods to prepare for your **Material Takeoff** and will be presented below:

Method 1

To generate quantity takeoff, say, for the **steel members** sorted by their sections, please refer to the following steps:

1. Go to **Drawings & Report tab** → **Material Takeoff** → **Prepare Material Takeoff**
2. Click **OK** on the Group Selector Dialog.
3. Two Quantity Takeoff Tables (with different formats) will automatically export as CSV files: the Summary Report and Quantity Takeoff based on the section length.
4. Repeat steps 1 to 3 for the other Material Lists option to export to the *CSV file*.

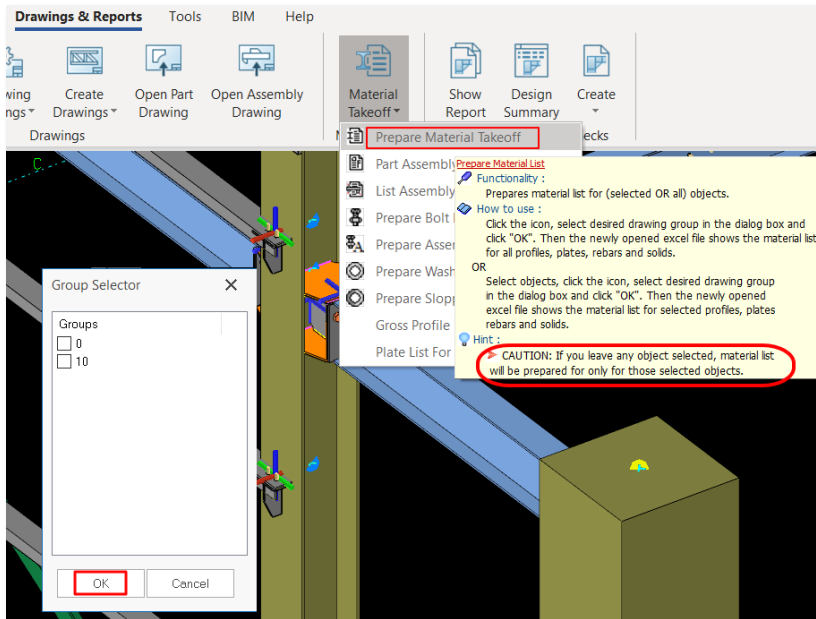

Section	Type	Material	Quantity	Length(m)	Cover	Area	Gross Weight	Net Weight(kgf)
1	L50X50X3	S355	15812	3.16	37.12	37.12		
2	L80X8	S355	11662	3.74	112.3	112.3		
3	RHS 150X75X3	S355	80390	70.69	829.21	829.21		
4	SHS 75X75X3	S355	70078	40.86	475.29	475.29		
5	UB 175X125X23	S355	25000	20.7	581.9	581.9		
6	UB 200X150X30	S355	57000	55.72	1705.2	1705.2		
7	UB 250X125X25	S355	30000	29.5	753.35	753.35		
8	UPN100	S355	150000	58.28	1613.55	1613.55		
9	UPN120	S355	120000	53.6	1629.73	1629.73		
Total				336.26	7737.65	7737.65		

Section	Type	Material	Quantity	Length(m)	Cover	Area	Gross Weight	Net Weight(kgf)
1	L50X50X3	S355	1	5281	1.06	12.4	12.4	
2	L50X50X3	S355	2	5265	2.11	24.72	24.72	
3	L50X50X3	S355	2	5265	2.11	24.72	24.72	
4		Subtotal		15812	3.16	37.12	37.12	
5	L80X8	S355	2	5831	3.74	112.3	112.3	
6		Subtotal		11662	3.74	112.3	112.3	
7	RHS 150X75X3	S355	4	10000	35.13	412.59	412.59	
8	RHS 150X75X3	S355	8	5049	35.56	416.62	416.62	
9		Subtotal		80390	70.69	829.21	829.21	
10	SHS 75X75X3	S355	8	2005	9.33	108.8	108.8	
11	SHS 75X75X3	S355	8	1885	8.78	102.3	102.3	
12	SHS 75X75X3	S355	8	1034	4.85	56.08	56.08	
13	SHS 75X75X3	S355	8	1819	8.47	98.68	98.68	
14	SHS 75X75X3	S355	4	1500	3.5	40.69	40.69	

Method 2

Method 2 generates a more detailed quantity takeoff with choices of categories to be included in the table. Please refer to the following steps:

- Go to **Drawings & Reports** → **Material Takeoff** → **Gross Profile Material List**
- Select corresponding format and units and click **Execute Report**.
- Click **Save** to export generated report as a CSV file.

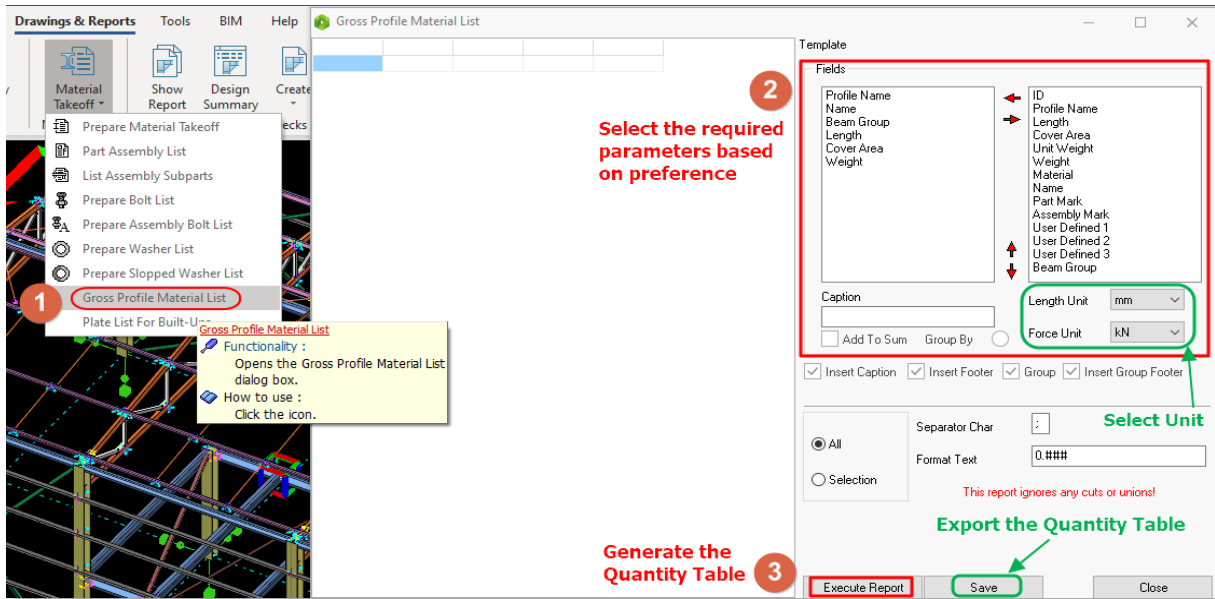

NC File Export

ProtaSteel can create the NC files for CNC machines to create the parts.

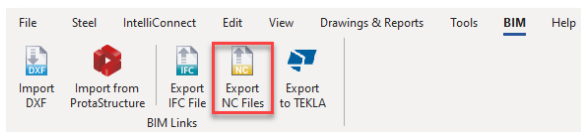

- Go to the BIM NC file export
- Select the items which you want to write on the steel members.
- Set the text height and direction parameters.
- Click "Run".

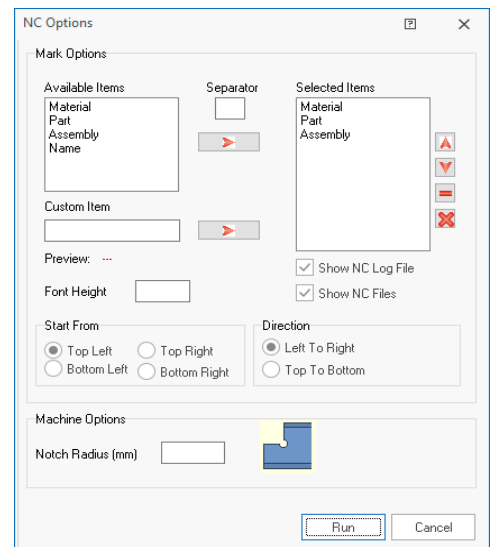

Numbering must be completed before creating the NC files.

Unsupported Situations:

- NC files cannot be created for pipe sections. The fish mount command can use for this issue.
- Plates must be Folded Plates.

The unsupported members will be added to the "not exported" list when files are exported.

Prepared NC files are located on the \Exports\NC\Plates or \Exports\NC\Profiles in the project folder.

IDEAStatica Integration

ProtaSteel has the feature of transferring data to the **IDEA Statica** which is a connection detailing program. With this feature, connections created with macros and user-defined complex connections can be transferred to the IDEA Statica program and connection calculations can be checked with the finite element method.

To export the connection type to IDEA Statica;

- Go to the BIM top menu and select the **“Run IDEA Statica Checkbot”**

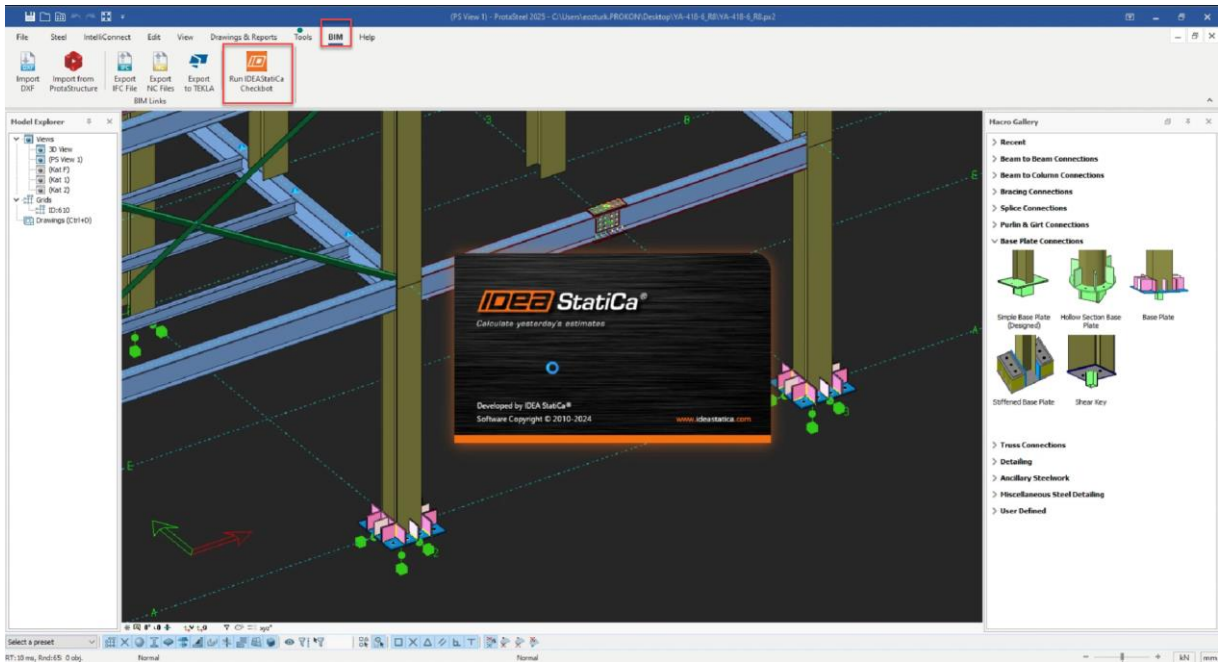

- Open IDEAStatica and create a new project file
- In IDEA Statica, go to the **“import”** menu and select the **“Bulk”**

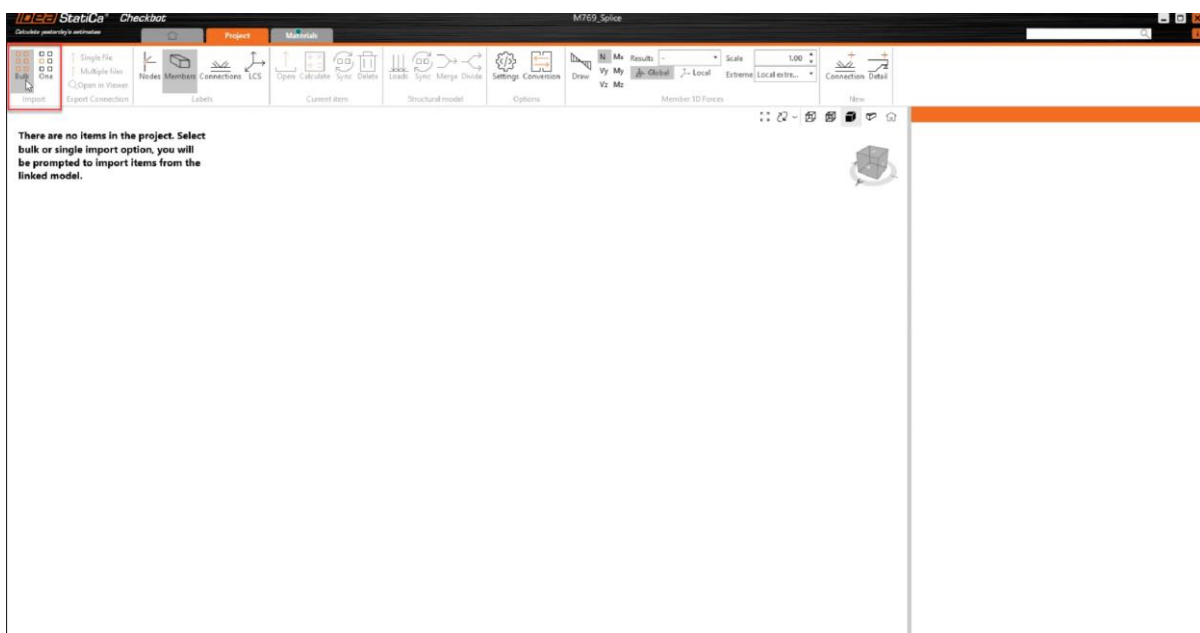

- Return to the **ProtaSteel** and pick the connection members.

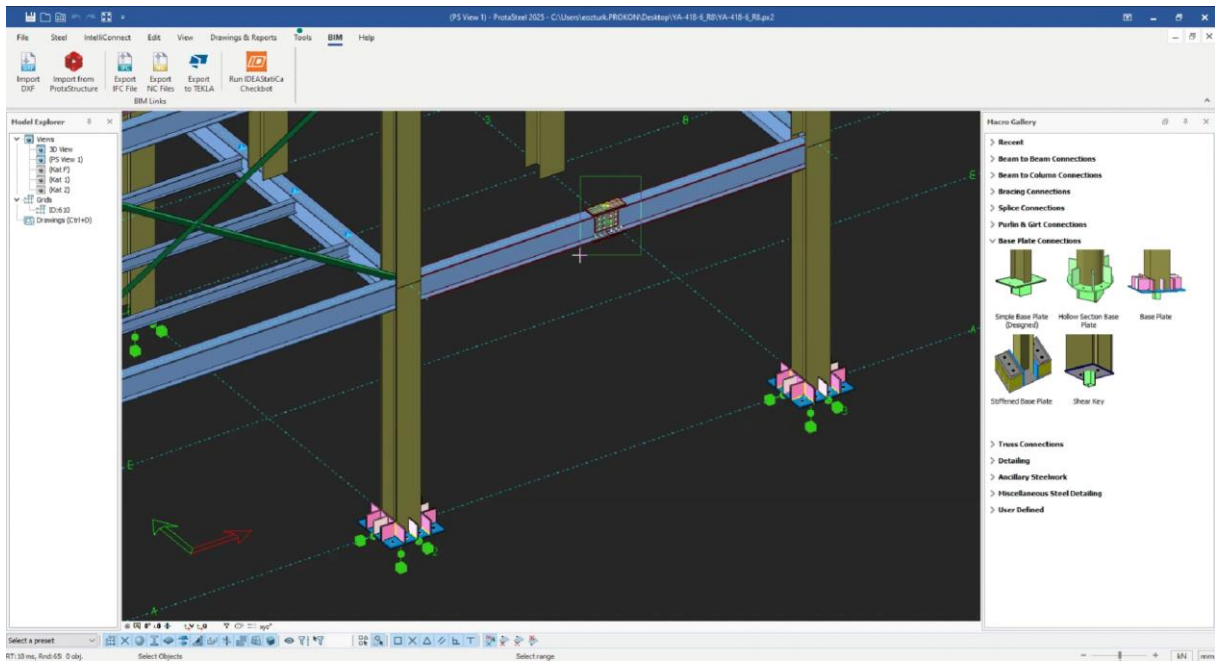

- The connection members export to the IDEA Statica. Internal forces of the structural members can be taken from the **ProtaStructure** and used in the IDEA Statica.

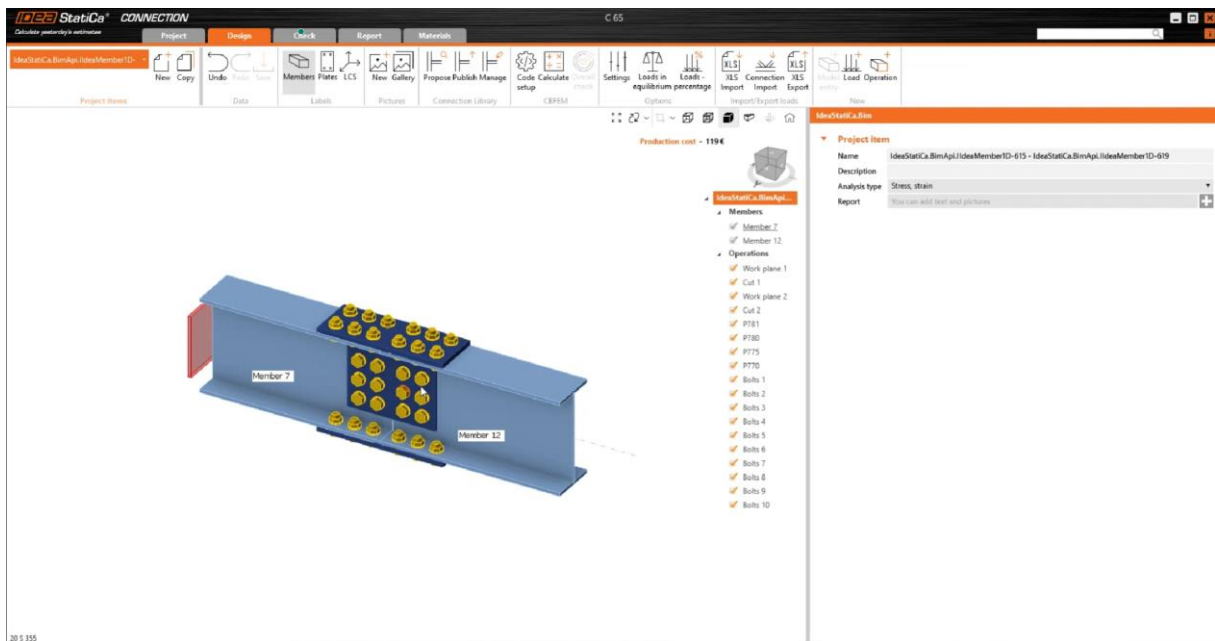

Closing Summary

Congratulations! You have completed your steel model & generated the engineering drawings in **ProtaSteel**.

In this Quick Start Guide, we have imported the **ProtaStructure** model into **ProtaSteel**. We then inserted ancillary steel members such as sag rods, adjusted members to their final positions, created some steel connections & generated the engineering drawings. This guide will give you the necessary knowledge to proceed to an actual project.

For more help and guidance, please refer to the **ProtaSteel** help reference accessible from the Help menu.

Alternatively, you can attend our training courses to obtain more in-depth knowledge of software usage. Please visit our website www.protasoftware.com for more information.

Thank You

Thank you for choosing the **Prota**Structure Suite product family.

Our top priority is to make your experience excellent with our software technology solutions.

Should you have any technical support requests or questions, please do not hesitate to contact us at all times through globalsupport@protasoftware.com and asiastsupport@protasoftware.com

Together with our responsive technical support team, our dedicated online support center is available to help you get the most out of **Prota**'s technology solutions.

The Prota Team

